



WARRANTY REGISTRATION
enviro.com/warranty

Q2GI / Q2GID

DIRECT VENT FIREPLACE - IPI

OWNER'S MANUAL



WARNING: If the information in this manual is not followed exactly, a fire or explosion may result causing property damage, personal injury or loss of life. Installation and service must be performed by a qualified installer, service agency or the gas supplier.

CERTIFIED TO: ANSI Z21.88 / CSA 2.33 VENTED GAS FIREPLACE HEATERS
CSA 2.17 GAS FIRED APPLIANCES FOR HIGH ALTITUDES

SAFETY PRECAUTIONS



WARNING:

FIRE OR EXPLOSION HAZARD

Failure to follow safety warnings exactly could result in serious injury, death, or property damage.

- **Do not store or use gasoline or other flammable vapors and liquids in the vicinity of this or any other appliance.**

- **WHAT TO DO IF YOU SMELL GAS**
 - **Do not try to light any appliance.**
 - **Do not touch any electrical switch; do not use any phone in your building.**
 - **Leave the building immediately.**
 - **Immediately call your gas supplier from a neighbor's phone. Follow the gas supplier's instructions.**
 - **If you cannot reach your gas supplier, call the fire department.**

- **Installation and service must be performed by a qualified installer, service agency or the gas supplier.**

INSTALLER:

Leave this manual with the appliance.

CONSUMER:

Retain this manual for future reference.

This appliance may be installed in an after-market permanently located, manufactured (mobile) home, where not prohibited by local codes.

This appliance is only for use with the type of gas indicated on the rating plate. This appliance is not convertible for use with other gases, unless a certified kit is used.

Massachusetts installations (Warning): This product must be installed by a licensed plumber or gas fitter when installed within the Commonwealth of Massachusetts. Other Massachusetts code requirements: Flexible connector must not be longer than 36in., a shut off valve must be installed; only direct vent sealed combustion products are approved for bedrooms/bathrooms. A carbon monoxide detector is required in all rooms containing gas fired direct vent appliances. The fireplace damper must be removed or welded in the open position prior to installation of a fireplace insert.

SAFETY PRECAUTIONS

FOR SAFE INSTALLATION AND OPERATION OF YOUR "ENVIRO" HEATER, PLEASE CAREFULLY READ THE FOLLOWING INFORMATION:

- All ENVIRO gas-fired appliances must be installed in accordance with their instructions. Carefully read all the instructions in this manual first. Consult the building authority having jurisdiction to determine the need for a permit prior to commencing the installation.
- **NOTE:** Failure to follow these instructions could cause a malfunction of the fireplace, which could result in death, serious bodily injury, and/or property damage.
- Failure to follow these instructions may also void your fire insurance and/or warranty.

GENERAL

• Installation and repair should be done by a qualified service person. The appliance should be inspected before the first use and, at least, annually by a qualified service person. More frequent cleaning may be required due to excessive lint from carpeting, bedding material, etc. It is imperative the control compartments, burners and circulating air passageways of the appliance be kept clean.

• Due to high temperatures, the appliance should be located out of high traffic areas and away from furniture and draperies.

Children and adults should be alerted to the hazards of high surface temperatures and should stay away to avoid burn or clothing ignition.

• Young children should be carefully supervised when in the same room as the appliance. Toddlers, young children and others may be susceptible to accidental contact burns. A physical barrier is required if there is a risk for individuals in the house. To restrict access to a fireplace or stove install an adjustable safety gate to keep toddlers, young children and other at risk individuals out of the room and away from hot surfaces. Any safety screen, guard, or barrier removed for servicing an appliance must be replaced prior to operating the appliance.

• Clothing or other flammable materials should not be placed on or near the appliance.

• A barrier designed to reduce the risk of burns from the hot viewing glass is provided with this appliance and shall be installed for the protection of children and other at-risk individuals. If the barrier becomes damaged, the barrier shall be replaced with the manufacturer's barrier for this appliance.

FOR YOUR SAFETY

• Installation and service must be performed by a qualified installer, service agency or gas supplier.

• This installation must conform to local codes or, in the absence of local codes, with the National Fuel Gas Code, ANSI Z223.1/NFPA 54, or the Natural Gas and Propane Installation Code, CSA B149.1.

• To prevent injury, do not allow anyone who is unfamiliar with the stove to operate it.

• To prevent injury, if the pilot or pilot and burners have gone out on their own, open the glass door and wait 5 minutes to air out before attempting to re-light the stove.

• Always keep the area around these appliances clear of combustible material, gasoline and other flammable liquids and vapours.

• These appliances should not be used as a drying rack for clothing or for hanging Christmas stockings/decorations.

• Due to the paint curing on the stove, a faint odor and slight smoking will likely be noticed when the stove is first used. Open a window until the smoking stops.

Always connect this gas stove to a vent system and vent to the outside of the building envelope. Never vent to another room or inside the building. Make sure the specified vent pipe is used, properly sized and of adequate height to provide sufficient draft. Inspect the venting system annually for blockage and signs of deterioration.

WARNING: Failure to position the parts in accordance with the diagrams in this booklet, or failure to use only parts specifically approved with this appliance, may result in property damage or personal injury.

WARNING: Do not operate with the glass front removed, cracked or broken. Replacement of the glass should be done by a licensed or qualified service person.

• Never use solid fuels such as wood, paper, cardboard, coal, or any flammable liquids, etc., in this appliance.

• Do not use this appliance if any part has been under water. Immediately call a qualified service technician to inspect the appliance and to replace any part of the control system or any gas control which has been under water.

• Do not abuse the glass by striking it or slamming the door shut.

• If the Q2GI / Q2GID unit is pulled out of its installation, and the vent-air intake system is disconnected for any reason, ensure that the vent-air intake pipes are reconnected and re-sealed in accordance to the instructions noted in INITIAL INSTALLATION - DIRECT VENT



DANGER



HOT GLASS WILL CAUSE BURNS

DO NOT TOUCH GLASS UNTIL COOLED.

NEVER ALLOW CHILDREN TO TOUCH GLASS.

A barrier designed to reduce the risk of burns from the hot viewing glass is provided with this appliance and must be installed for the protection of children and other at-risk individuals.

TABLE OF CONTENTS

Safety Precautions.....	2
Table of Contents.....	4
Codes And Approvals.....	5
Specifications.....	6
Dimensions.....	6
Rating Label Location.....	6
Operating Instructions.....	7
Lighting and Turning Off Instructions.....	7
Air Shutter.....	8
Normal Sounds During Operation.....	8
Remote Control Operation.....	8
Initializing the System for the First Time.....	11
Switching to Continuous Pilot.....	11
Fan Control.....	13
Maintenance And Service.....	14
Routine Maintenance.....	14
Cleaning The Glass.....	14
Cleaning The Firebox.....	14
Replacing the Glass.....	14
Cleaning Decorative Surfaces.....	15
Glass Door Removal.....	16
Burner Removal.....	16
Access Door.....	16
Fuel Conversion.....	17
Conversion Kit Installation.....	18
Initial Installation.....	20
Introduction.....	20
Placement and Framing.....	20
Framing Plate Installation.....	21
Mantle and Non-Combustible Clearances.....	22
Corner Installation.....	23
Direct Vent.....	23
Vent Termination Restrictions.....	25
Venting Clearances.....	26
Approved Venting Parts.....	26
Allowable Co-Axial Vent Configurations.....	28
Horizontal Termination.....	30
Vertical Termination.....	31
Gas Line Connection and Testing.....	34
Electrical Requirements.....	35
Secondary Installation.....	36
Glass Media Installation.....	36
Optional Driftwood Log Set Installation.....	36
Trouble Shooting.....	37
Parts List.....	39
Parts Diagram.....	40
Notes.....	41
Warranty.....	43
Installation Data Sheet.....	44

CODES AND APPROVALS

DIRECT VENT ONLY: This type is identified by the acronym "DV". This appliance draws all of its air for combustion from outside the dwelling, through a specially designed vent pipe system.

This appliance has been tested and approved for installations from 0 feet to 4500 feet (1372 m) above sea level.

In the USA: The appliance may be installed at higher altitudes. Please refer to your American Gas Association guidelines which state: the sea level rated input of Gas Designed Appliances installed at elevations above 2000 (610 m) feet is to be reduced 4% for each 1000 feet (305 m) above sea level. Refer also to local authorities or codes which have jurisdiction in your area regarding the de-rate guidelines.

In Canada: When the appliance is installed at elevations above 4500 feet (1372 m), the certified high altitude rating shall be reduced at the rate of 4% for each additional 1000 feet (305 m).

- This appliance has been tested by INTERTEK and found to comply with the established VENTED GAS FIREPLACE HEATER standards in CANADA and the USA as follows:

VENTED GAS FIREPLACE HEATER (Q2GI / Q2GID; NATURAL GAS, PROPANE GAS)

TESTED TO: ANSI Z21.88 / CSA 2.33 VENTED GAS FIREPLACE HEATERS

CAN/CGA 2.17 GAS FIRED APPLIANCES FOR HIGH ALTITUDES

This ENVIRO Q2GI / Q2GID Fireplace:

- Has been certified for use with either natural gas or propane (see rating label).
- Is not for use with solid fuels.
- Is approved for bedroom or bed sitting room. (**IN CANADA:** must be installed with a listed wall thermostat. **IN USA:** see current ANSI Z223.1 for installation instructions.)
- Must be installed in accordance with local codes. If none exist, use current installation code CAN/CGA B149 in Canada or ANSI Z223.1/NFPA 54 in the USA.
- Must be properly connected to an approved venting system and not connected to a chimney flue serving a separate solid-fuel burning appliance.

IMPORTANT NOTICE (Regarding first fire up): When the unit is turned on for the first time, it should be turned onto high without the fan on (if equipped) for the first 4 hours. This will cure the paint, logs, gasket material and other products used in the manufacturing process. It is advisable to open a window or door, as the unit will start to smoke and can irritate some people. After the unit has gone through the first burn, turn the unit off including the pilot, let the unit get cold then remove the glass door and clean it with a good gas fireplace glass cleaner, available at your local ENVIRO dealer.

**NATIONAL
FIREPLACE
INSTITUTE®**



CERTIFIED

www.nficertified.org

We recommend that our gas hearth products be installed and serviced by professionals who are certified in the U.S. by the National Fireplace Institute® (NFI) as NFI Gas Specialists.

SPECIFICATIONS

DIMENSIONS:

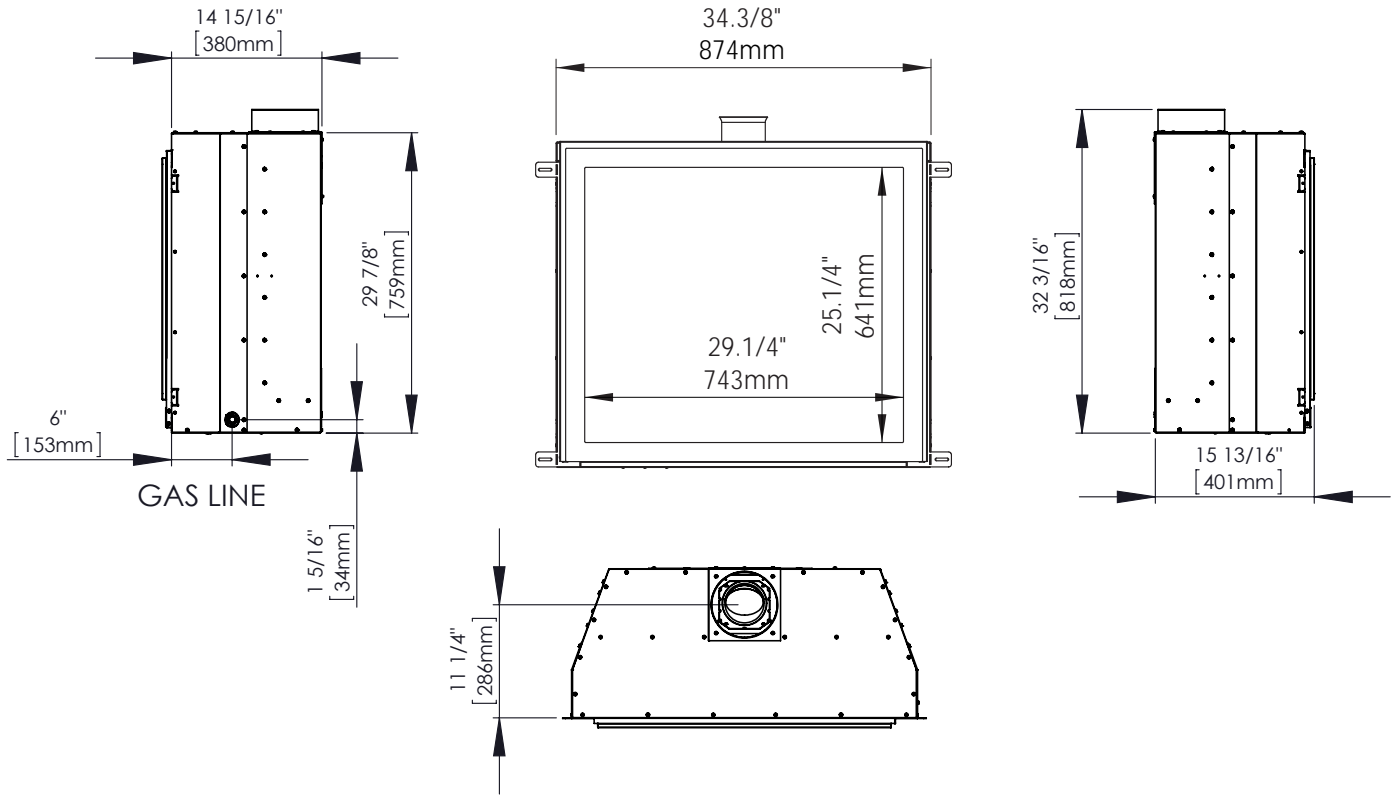

Figure 1. Q2GI / Q2GID Dimensions - Top Vent

RATING LABEL & LIGHTING INSTRUCTIONS LOCATION:

To access the rating label and lighting instructions flip down the control cover. The plates are attached to a length of chain and are never to be tampered with or removed. All important information for your fireplace is on this label as well of the model specific serial number which you will need for warranty information.

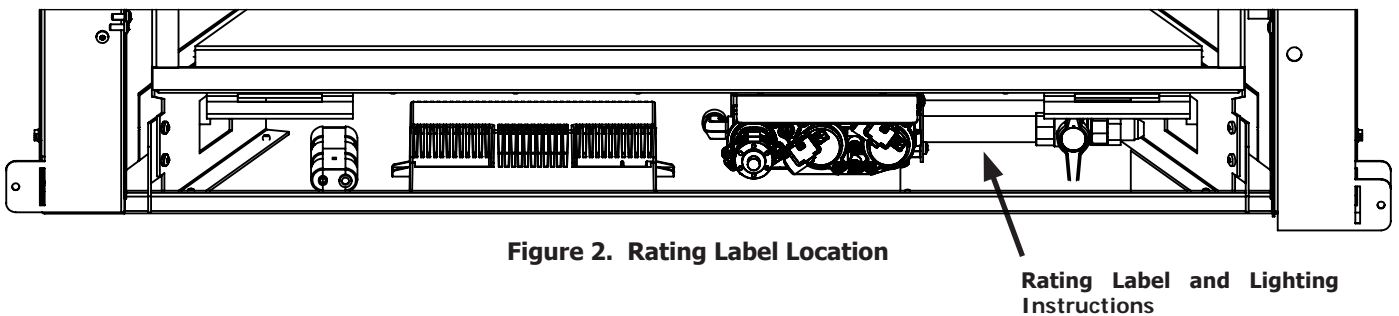

Figure 2. Rating Label Location

OPERATING INSTRUCTIONS

For Your Safety, Read Safety Precautions And Lighting Instructions Before Operating

WARNING: IF YOU DO NOT FOLLOW THESE INSTRUCTIONS EXACTLY A FIRE OR EXPLOSION MAY RESULT, CAUSING PROPERTY DAMAGE, PERSONAL INJURY OF LOSS OF LIFE.

LIGHTING AND TURNING OFF INSTRUCTIONS:

FOR YOUR SAFETY READ BEFORE OPERATING

WARNING: IF YOU DO NOT FOLLOW THESE INSTRUCTIONS EXACTLY, A FIRE OR EXPLOSION MAY RESULT CAUSING PROPERTY DAMAGE, PERSONAL INJURY OR LOSS OF LIFE.

- A. This appliance is equipped with an ignition device which automatically lights the pilot. Do not try to light the pilot by hand.
- B. BEFORE OPERATING smell all around the appliance area for gas. Be sure to smell next to the floor because some gas is heavier than air and will settle on the floor.
- WHAT TO DO IF YOU SMELL GAS:
- Do not try to light any appliance.
 - Do not touch any electrical switch; do not use any phone in your building.
 - Immediately call your gas supplier from a neighbor's phone. Follow the gas supplier's instructions.
 - If you cannot reach your gas supplier, call the fire department.
- C. Use only the remote supplied with this fireplace. Never use tools, don't try to repair it, call a qualified service technician. Force or attempted repair may result in a fire or explosion.
- D. Do not use this appliance if any part has been under water. Immediately call a qualified service technician to inspect the appliance and to replace any part of the control system and any gas control which has been under water.

OPERATING INSTRUCTIONS

1. STOP! Read the safety information above on this label.
2. Read the owner's manual including the section on "Remote Control" operation.
3. Turn off all electric power to the appliance.
4. Do not attempt to light the pilot by hand.
5. Wait five (5) minutes to clear out any gas. Then smell for gas, including near the floor. If you smell gas, STOP! Follow "B" in the safety information above on this label. If you don't smell gas, go to the next step.
6. Turn on all electric power to the appliance.
7. Using the remote control, press the ON/OFF key on the remote. "ON" will be indicated on the display of the remote and an audible "beep" will be heard at the unit to indicate the command has been received.

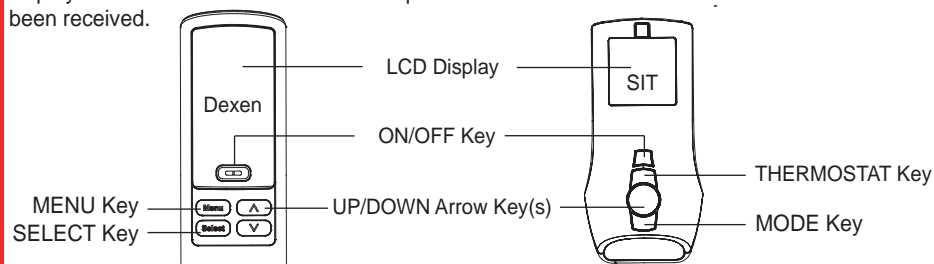

8. If the appliance will not operate, follow the instructions "To Turn Off Gas To Appliance" and call your service technician or gas supplier.

TO TURN OFF GAS TO APPLIANCE

1. Set thermostat to lowest setting, or press the ON/OFF or Power Key. "OFF" will be indicated on the display and an audible "Beep" will be heard at the unit to indicate the command has been received.
2. Turn off all electric power to the appliance if service is to be performed.

C-16320

Figure 3. Lighting Instruction Label

OPERATING INSTRUCTIONS

AIR SHUTTER:

The air shutter adjustment lever is on the right hand side of the control area (see Figure 4).

The air shutter allows the amount of air coming into the fireplace to be adjusted in order to accommodate different climates and venting arrangements. Start the pilot and then the burner. Make sure the pilot flame is burning normally and none of the burner ports are plugged. Let the fireplace burn for roughly fifteen minutes and make adjustments as necessary.

The ideal flame will be blue at the base and light orange above. The flames should be of medium height. If the flames look like this, no venturi adjustment is needed. If the flames are fairly short and

mostly blue, the fireplace is getting too much air. Therefore, the air shutter should be closed (pulled out) slightly until the correct flames are achieved. Flames that are very orange, with tall, dark, stringy tips, are not getting enough air. Open (push in) the venturi until the flames clean up. If the venturi is opened, or closed all the way, and the correct flames cannot be attained, turn off the gas and contact the dealer.

Warning: Incorrect venturi adjustment may lead to improper combustion, which is a safety hazard. Contact the dealer if there is any concern about the venturi adjustment.

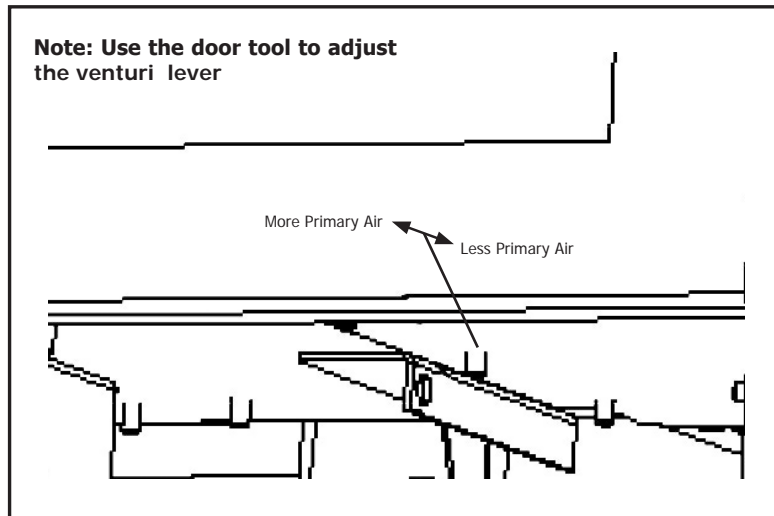

Figure 4. Air shutter adjustment lever.

NORMAL SOUNDS DURING OPERATION:

Table 1: Normal Sounds

Component	Sound & Reason
Fireplace Body	Creaking when heating up or cooling down.
Burner	Light pop or poof when turned off; this is more common with LP units.
Temperature Sensor	Clinking when it senses to turn the blower on or off.
Pilot Flame	Quiet whisper while the pilot flame is on.
Blower / Fan	Air movement that increases and decreases with the speed of the blower. The blower is pushing the heat from the fireplace into the room.
Gas Control Valve	Dull click when turning on or off, this is the valve opening and closing.

OPERATING INSTRUCTIONS



For Q2GID models refer to the separate Dexen user manual supplied for remote control operations.

REMOTE CONTROL OPERATIONS:

Proflame 2 is a modular remote control system that directs the functions of the fireplace. The Proflame 2 TMFSLA is configured to control the on/off main burner operation, its flame levels and provides on/off and Smart thermostatic control of the appliance. The system also controls the fan speed through six (6) levels.

SYSTEM DESCRIPTION:

The Proflame 2 Remote Control System consists of two (2) elements:

1. Proflame 2 Transmitter.
2. Integrated Fireplace Controller (IFC) and a wiring harness to connect to the gas valve and stepper motor.

ATTENTION!

- TURN "OFF" THE MAIN GAS SUPPLY OF THE APPLIANCE DURING INSTALLATION OR MAINTENANCE OF THE IFC.
- TURN "OFF" MAIN GAS SUPPLY TO THE APPLIANCE PRIOR TO REMOVING OR REINSERTING THE BATTERIES IN THE BATTERY HOLDER

TECHNICAL DATA

Transmitter (Remote Control):

Supply voltage: 4.5 V (three 1.5 V AAA batteries)
Radio frequency: 315 MHz

Integrated Fireplace Controller (IFC):

Supply voltage: AC IN - 120 V / 60 Hz
Battery Backup IN - 6 Vdc - 200mA (four 1.5 V AA batteries)
Spark voltage / frequency: >10kV / 1Hz
Comfort modulating fan: 120 V / 60 Hz / 2A
Auxiliary: 120 V / 60 Hz / 5A (not used)

TRANSMITTER:

The Proflame 2 Transmitter is a black remote control with a blue backlit LCD display. It uses a streamline design with a simple button layout and informative LCD readout (Figure 6). The Transmitter is powered by three (3) AAA type batteries. A Mode Key is provided to Index between the features and a Thermostat Key is used to turn on/off or index through Thermostat functions (Figure 5 & 6)

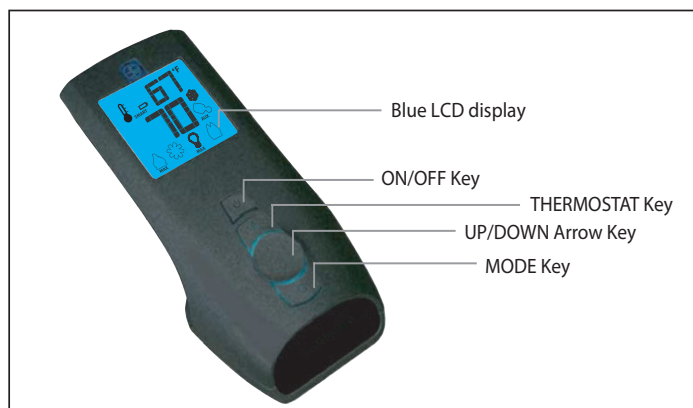

Figure 5: Proflame 2 Transmitter.

OPERATING INSTRUCTIONS

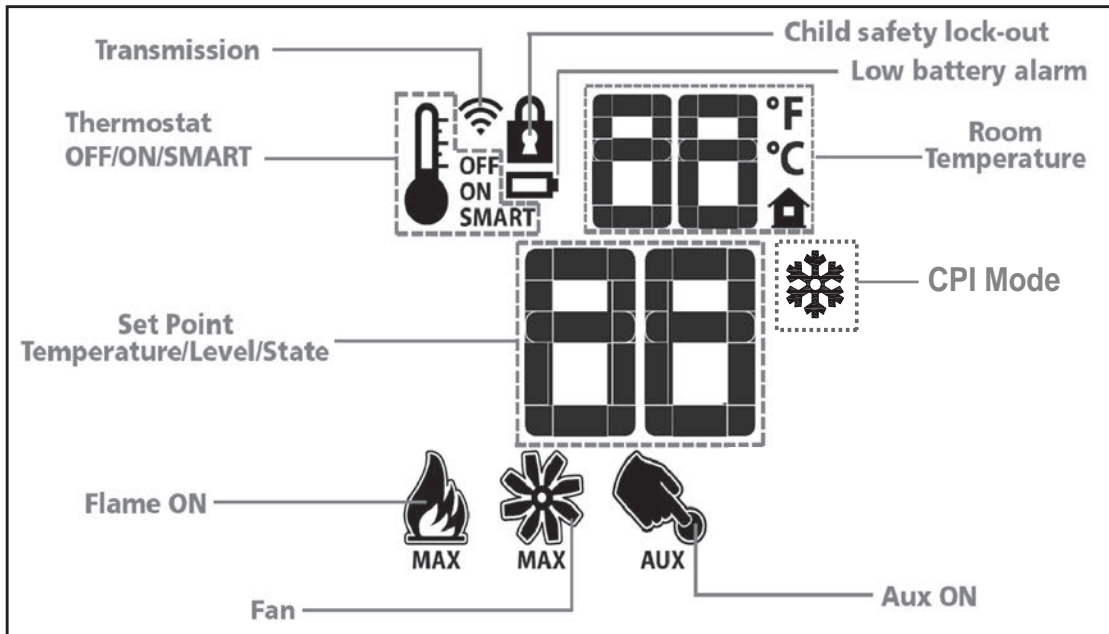
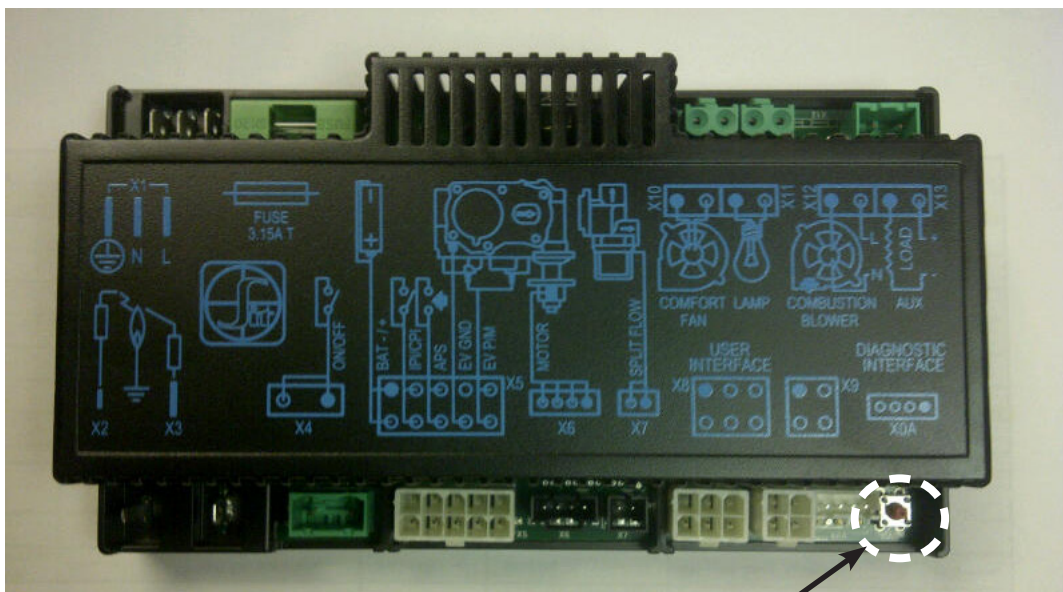

Figure 6: Proflame 2 Transmitter LCD Screen.

INTEGRATED FIREPLACE CONTROLLER (IFC):

The Proflame 2 IFC (Figure 7) connects directly to the gas valve, stepper motor, pilot, and convection fan with a wiring harness. The IFC is mainly powered by 120 VAC but can also run off a battery backup four (4) AA type batteries for shorter periods of time. The IFC accepts commands via radio frequency from the Transmitter to operate the appliance in accordance with the particular Proflame 2 system configuration. The IFC has a red reset button at the front right corner that is used to synchronize the Transmitter when using the for the first time, or after the batteries have been replaced.



Reset Button

Figure 7: Integrated Fireplace Controller

OPERATING INSTRUCTIONS

OPERATING PROCEDURE:

Initializing The System For The First Time

Install the four (4) AA batteries into the IFC battery holder. Note the polarity of the battery and insert into the battery bay as indicated on the body of the battery holder. Press the reset button on the IFC marked "SW1" (see Figure 7).

The IFC will "beep" three (3) times to indicate that it is ready to synchronize with a Transmitter. Install the three (3) AAA type batteries in the Transmitter battery bay, located on the base of the Transmitter. With the batteries already installed in the Transmitter, push the 'ON' button. The IFC will "beep" four (4) times to indicate the Transmitter's command is accepted and sets to the particular code of that Transmitter. The system is now initialized.

Temperature Indication Display

With the system in the "OFF" position, press the Thermostat Key and the Mode Key at the same time. Look at the LCD screen on the transmitter to verify that a °C or °F is visible to the right of the Room Temperature display (see Figure 8).

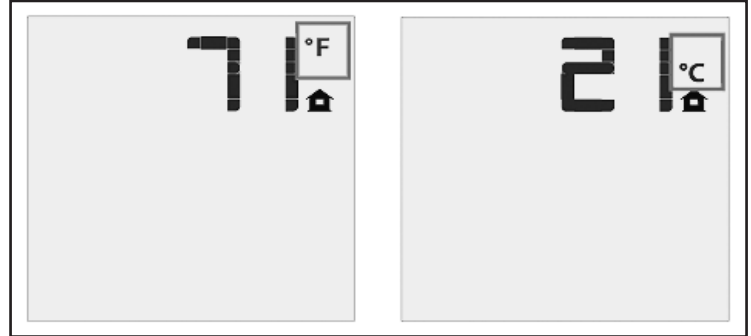

Figure 8: Remote Control Display in Farenheit and Celcius.

Turn on the Appliance

Press the ON/OFF Key on the Transmitter. The Transmitter display will show all active Icons on the screen. A single "beep" from the Receiver will confirm reception of the command and will commence to first ignite the pilot light, followed by the main burner. This should take about 10 seconds to complete.

SWITCHING TO CONTINUOUS PILOT MODE:

When the Q2GI is turned off press the mode key to index to the constant pilot (CPI) mode icon (see figure 9). Pressing the up arrow key will select Continuous Pilot Ignition (CPI) and pressing the down arrow key will return to IPI. Once a selection is made the IFC will beep once to confirm it had received the command. **NOTE: It is recommended to use the continuous pilot mode during the winter when the outside temperature is below 50°F (10°C) to keep the chimney properly heated for updraft during burner ignition.** Continuous pilot mode also keeps the firebox warm which eliminates both heat loss to cold air that is trapped inside the firebox as well as excessive exhaust vapour condensation on the door glass.

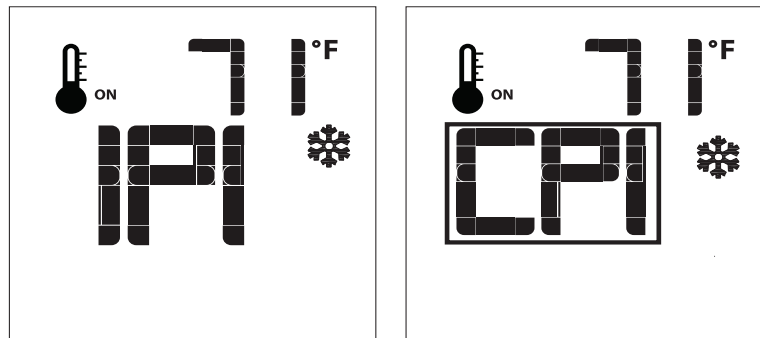

Figure 9: CPI Pilot Mode.

OPERATING INSTRUCTIONS

Turn off the Appliance

Press the ON/OFF Key on the Transmitter. The Transmitter LCD display will only show the room temperature and Icon (see Figure 10). A single "beep" from the IFC confirms reception of the command and both the pilot light (if the unit is not set to continuous pilot) and main burner will turn off.

Room Thermostat (Transmitter Operation)

The Remote Control can operate as a room thermostat. The thermostat can be set to a desired temperature to control the comfort level in a room. To activate this function, press the Thermostat Key (see Figure 5). The LCD display on the Transmitter will change to show that the room thermostat is "ON" and the set temperature is now displayed (see Figure 10). To adjust the set temperature, press the Up or Down Arrow Keys until the desired set temperature is displayed on the LCD screen of the Transmitter.

Smart Thermostat (Transmitter Operation)

The Smart Thermostat function adjusts the flame height in accordance to the difference between the set point temperature and the actual room temperatures. As the room temperature gets closer to the set point the Smart Function will modulate the flame down. To activate this function, press the Thermostat Key (Figure 5) until the word "SMART" appears to the right of the temperature bulb graphic (Figure 11). To adjust the set temperature, press the Up or Down Arrow Keys until the desired set temperature is displayed on the LCD screen of the Transmitter.

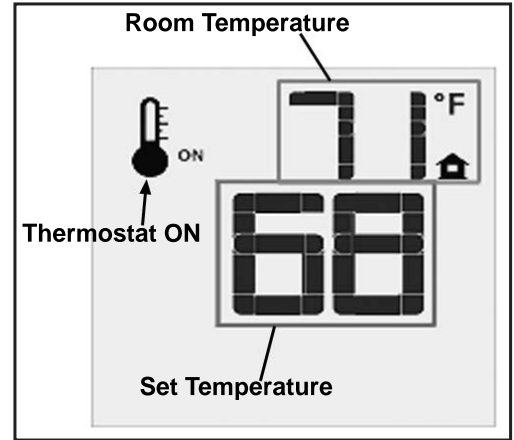

Figure 10: Remote Control Displays Set Temperature.

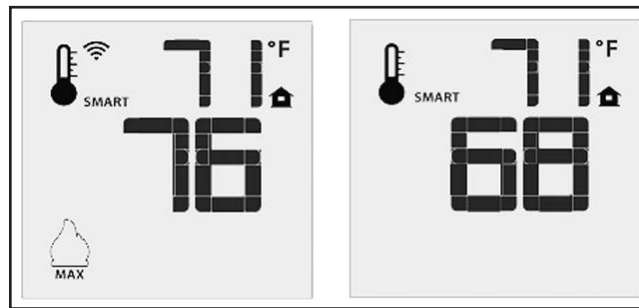

Figure 11: Remote Control's Smart Flame Function.

Remote Flame Control

The Proflame 2 GTMF has six (6) flame levels. With the system on, and the flame level at the maximum in the appliance, pressing the Down Arrow Key once will reduce the flame height by one step until the flame is turned off. The Up Arrow Key will increase the flame height each time it is pressed. If the Up Arrow Key is pressed while the system is on but the flame is off, the flame will come on in the high position (refer to Figure 12). A single "beep" will confirm reception of the command.

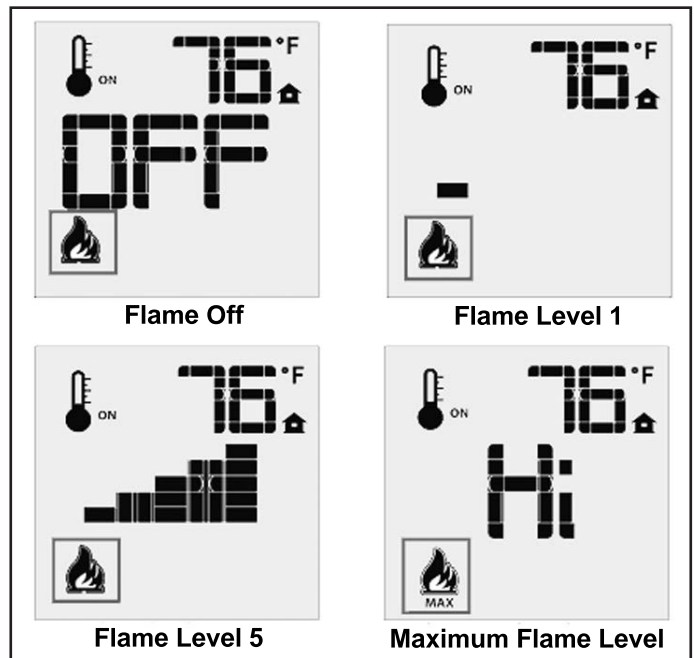

Figure 12: Remote Control's Flame Levels.

OPERATING INSTRUCTIONS

Fan Control

The Q2GI comes with a convection fan that can be controlled with the Transmitter. The fan speed can be adjusted through six (6) speeds. To control the fan press the MODE key (Figure 5) to index to the fan control icon (Figure 13). Use the UP/DOWN arrow keys to turn on, off, or adjust the fan speed (Figure 13). A single beep from the IFC will confirm the command has been received

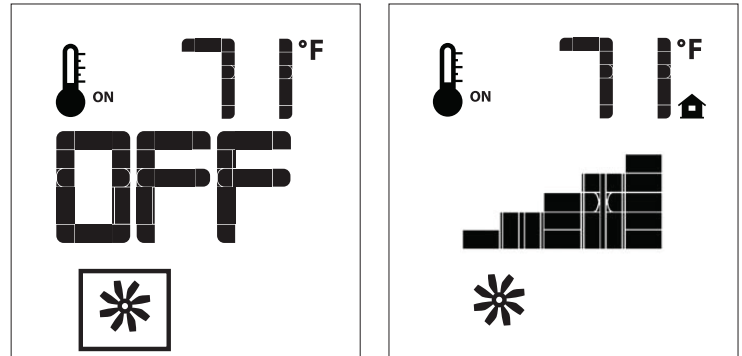

Figure 13: Fan Control

Key lock

This function will lock the keys to avoid unsupervised operation. To activate this function, press the MODE and UP keys at the same time and the a lock will appear (see Figure 15). To de-activate this function, press the MODE and UP Keys at the same time.

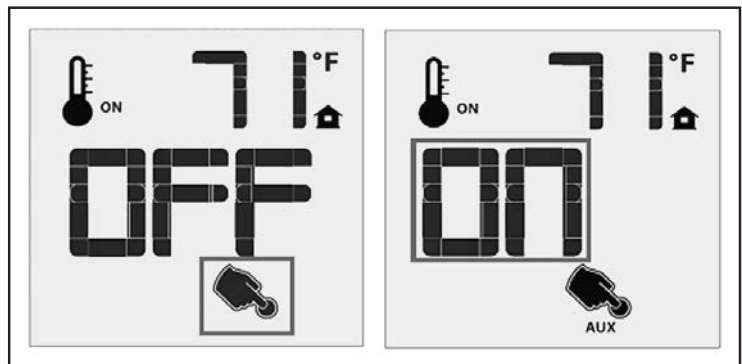

Figure 14: Remote Control with Aux (not used)

Low Battery Power Detection

Transmitter: The life span of the remote control batteries depends on various factors: quality of the batteries used, the number of ignitions of the appliance, the number of changes to the room thermostat set point, etc. When the Transmitter batteries are low, a Battery Icon will appear on the LCD display of the Transmitter (see Figure 16) before all battery power is lost. When the batteries are replaced this Icon will disappear.

IFC: The life span of the IFC batteries depends on various factors during a prolonged power outage: quality of the batteries used, the number of ignitions of the appliance, the number of changes to the room thermostat set point etc. When the IFC batteries are low, No "beep" will be emitted when it receives an On/Off command from the Transmitter. This is an alert for a low battery condition for the IFC. When the batteries are replaced the "beep" will be emitted from the Receiver when the ON/OFF Key is pressed (See INITIALIZING THE SYSTEM FOR THE FIRST TIME).



Figure 15: Remote Control Locked.

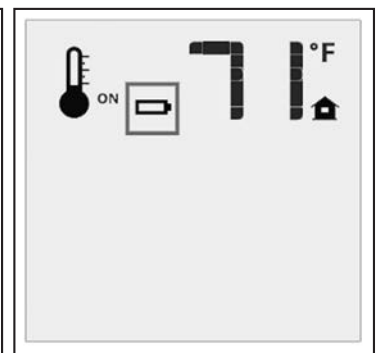

Figure 16: Low Battery Indicator.

WARNING: Fire Hazard. Can cause severe injury or death The Receiver causes ignition of the appliance. The appliance can turn on suddenly. Keep away from the appliance burner when operating the remote system or activating manual by pass of the remote system.

WARNING: Shock Hazard. Can cause severe injury or death. This device is powered by line voltage. Do not try to repair this device. In no way is the enclosure to be tampered with or opened. Disconnect from line voltage before performing any maintenance.

WARNING: Devices rated more than 5A shall not be connected to the OUT receptacle. Devices rated more than 1A shall not be connected to the FAN receptacle. Devices rated more than 2A shall not be connected to the AUX receptacle.

CAUTION: Property Damage Hazard. Excessive heat can cause property damage. The appliance can stay lit for many hours. Turn off the appliance if it is not going to be attended for any length of time. Always place the Transmitter where children cannot reach it.

MAINTENANCE AND SERVICE

ROUTINE MAINTENANCE:

At least once a year, run through the following procedures to ensure the system is clean and working properly. Check the burner to see if all the ports are clear and clean. Check the pilot to make sure it is not blocked by anything. The pilot flame should be blue with little or no yellow on the tips.

Warning: Clearances must be sufficient to allow access for maintenance and service

Warning: Failure to position the parts in accordance with this manual, or failure to use only parts specifically approved with this appliance may result in property damage or personal injury.

The venting system must be periodically examined; it is recommended the examination is done by a qualified agency.

CLEANING THE GLASS:

When the fireplace has cooled, remove the face of the fireplace (if applicable) along with the glass door. See MAINTENANCE AND SERVICE - GLASS DOOR REMOVAL. Check the gasket material on the back of the glass, making sure that it is attached and intact.

During a cold start up, condensation will sometimes form on the glass. This is a normal condition with all gas fireplaces. However, this condensation can allow dust and lint to cling to the glass surface. Initial paint curing of the appliance can leave a slight film behind the glass, a temporary problem. The glass will need cleaning about two weeks after installation. **Use a mild glass cleaner and a soft cloth. Abrasive cleaners will damage the glass and painted surfaces.** Depending on the amount of use, the glass should require cleaning no more than two or three times a season. **Do not clean the glass when it is hot.**

CLEANING THE FIREBOX:

Remove all of the glass media from the tray, a vacuum cleaner with an empty canister or new bag works best. At this time, inspect the burner tray for cracking or severe warping. If a problem is suspected, contact the dealer. Check the glass media for large amounts of soot; a small amount on the bottom side of the glass is normal. Re-install the glass as in the Secondary Installation - Glass Media Installation section. If new or glass is required, contact your nearest ENVIRO dealer.

REPLACING THE GLASS:

The glass in the fireplace is a high temperature ceramic. If the glass is damaged in any way, a factory replacement is required (see PARTS LIST). Wear gloves when handling damaged glass door assembly to prevent personal injury. Do not operate with the glass front removed, cracked or broken. Removal and replacement of the glass from the door **must** be done by a licensed or qualified service person. **The glass must be purchased from an ENVIRO dealer. No substitute materials are allowed.** Remove the door (see page 15). The replacement glass will come with a new gasket installed. Remove any silicone remnants from the door. Apply high temperature silicone to all four faces of the door and install the new piece of glass with gasket (be sure to maintain edge clearances). Apply even pressure to the glass to allow the silicone to adhere to the gasket material.

MAINTENANCE AND SERVICE

CLEANING DECORATIVE SURFACES:

Painted and porcelain faces should be wiped with a damp cloth periodically. If a plated face has been purchased, it should be unpacked/unwrapped carefully to avoid getting anything on the surface of the finish, including cleaners, polish and finger prints. It is important to note that fingerprints and other marks can leave a permanent stain on plated finishes. **To avoid this, give the face a quick wipe with denatured alcohol on a soft cloth BEFORE lighting the fireplace.** Never clean the face when it is hot. Do not use other cleaners as they may leave a residue, which can become permanently etched into the surface.

GLASS DOOR REMOVAL:

The door will occasionally need to be removed for installation of media, and cleaning of the Glass.

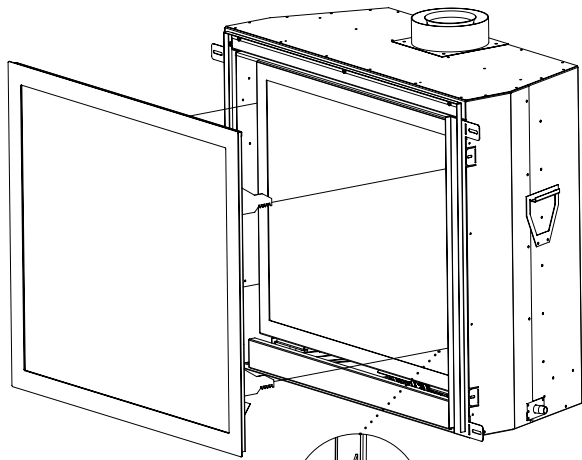

Figure 8. Safety Screen Mounts 4 positions

Step 1. First remove the safety screen by grabbing the top and bottom of the frame and lifting it up and out.

Step 2. To remove the glass door use your two index fingers to pull the spring latches up over the two door tabs. Fig.18A

Step 3. Once released, pivot the door forward and pull it out of the bottom door retainers. The door must be angled in order for it to pull out. Fig.18B

To replace the glass door, simply reverse the above procedure.

WARNING: Do not touch or attempt to remove the glass door if the fireplace is not completely cold.

WARNING: Never operate the fireplace without the glass door

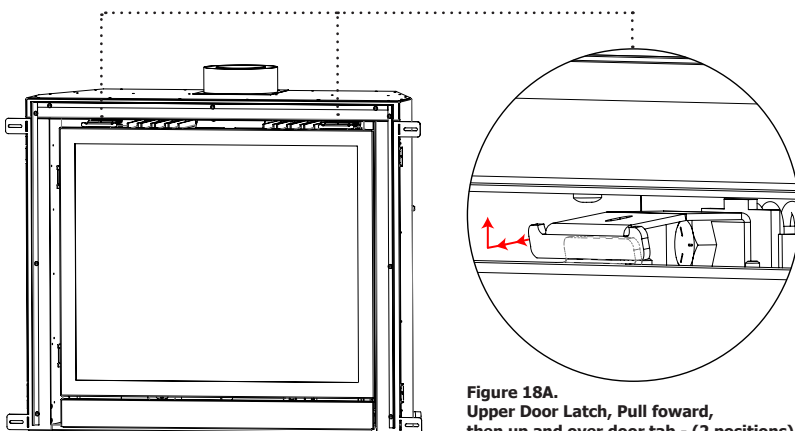

Figure 18A. Upper Door Latch, Pull forward, then up and over door tab - (2 positions)

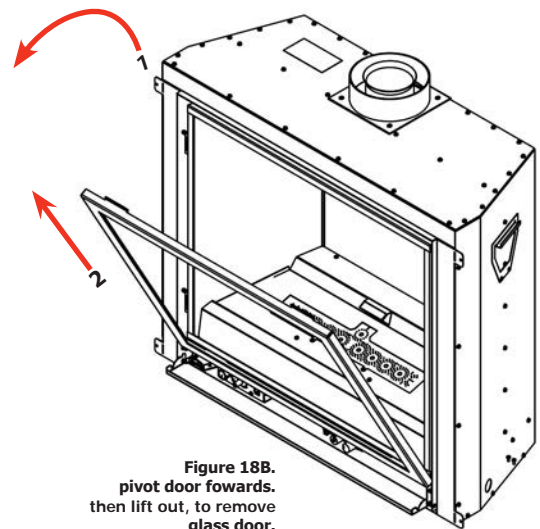

Figure 18B. pivot door forwards. then lift out, to remove glass door.

MAINTENANCE AND SERVICE

BURNER REMOVAL:

The burner may need to be removed for a few reasons, including cleaning under the burner or fuel conversion. **Proceed only when the unit has completely cooled down.**

Step 1: Remove the glass door as shown in the MAINTENANCE AND SERVICE - GLASS DOOR REMOVAL.

Step 3: Unscrew the burner pan using a T20 screwdriver then rotate it clockwise and pull it out of the venturi box (Figure 19).

To re-install the burner follow steps 1-3 in reverse. When placing the burner back in the unit be sure not to move the air shutter.

Step 2: Remove the glass media and the enameled glass tray as shown in Figure 20.

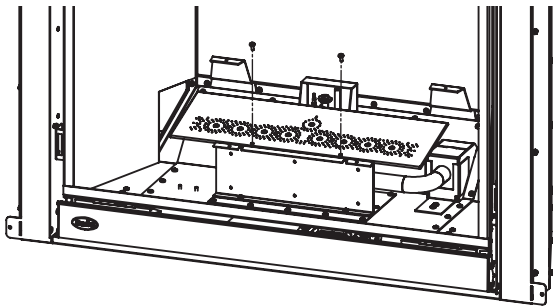

Figure 19. Removing Burner

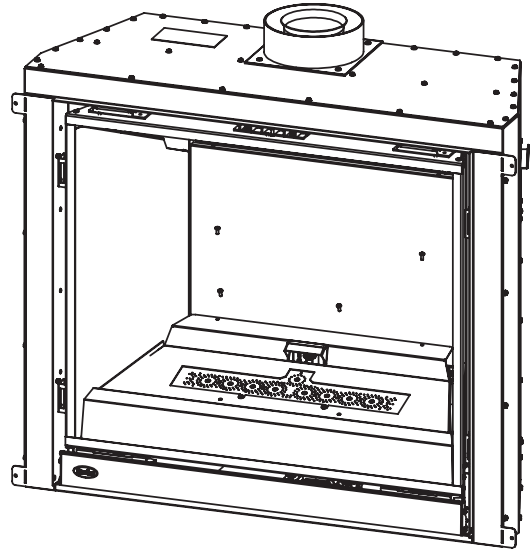

Figure 20. Removing Glass Tray

ACCESS DOOR:

There is an access door in the bottom on the firebox that is used for servicing components after the unit is installed in a construction enclosure. **Proceed only when the unit has completely cooled down.**

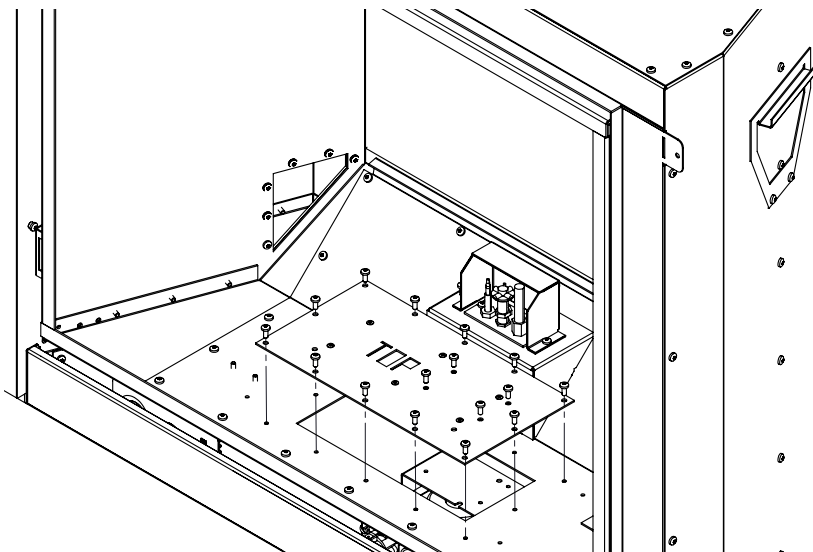

Figure 21. Removing Access Door

Step 1: Remove the burner as shown in the MAINTENANCE AND SERVICE - BURNER REMOVAL.

Step 2: Remove the Upper Air Diverter by removing (2) T-20 bolts. Remove the Lower Air Diverter.

Step 3: Remove the right and left burner stands by removing (4) T-20 bolts.

Step 4: Remove the (16) T-20 bolts retaining the access door as shown in Figure 21.

Step 5: After servicing assemble in the reverse order and be sure the gasket is still intact. Replace if necessary.

MAINTENANCE AND SERVICE

FUEL CONVERSION:

TO BE INSTALLED BY A QUALIFIED SERVICE AGENCY ONLY

Please read and understand these instructions before installing.

Warning: This conversion kit shall be installed by a qualified service agency in accordance with the manufacturer's instructions and all applicable codes and requirements of the authority having jurisdiction. If the information in these instructions is not followed exactly, a fire, explosion or production of carbon monoxide may result causing property damage, personal injury or loss of life. The qualified service agency is responsible for the proper installation of this kit. The installation is not proper or complete until the operation of the converted appliance is checked as specified in the manufacturer's instructions supplied with the kit.

Kit Parts List for all Q2GI Models:

- 1 - Orifice (NG - #40 DMS or LP - #55 DMS) as marked
- 1 - Pilot Orifice (NG: 0.2) or (LP: 0.14)
- 1 - Stepper Regulator with diaphragm
- 1 - Installation instruction sheet
- 1 - Conversion label

Carefully inspect all parts supplied with this conversion kit. If any parts have been damaged or are missing, contact your dealer to have them replaced before starting this installation.

MODEL: Q2GI; Q2LI

THIS APPLIANCE WAS CONVERTED ON: _____ DD/MM/YYYY

TO (LPG) PROPANE WITH KIT NO. 50-3061

BY: _____

(NAME AND ADDRESS OF ORGANIZATION MAKING THIS CONVERSION),
WHICH ACCEPTS RESPONSIBILITY THAT THIS CONVERSION HAS BEEN
PROPERLY MADE.

Max Input: 20,000 Btu/hr (5.86KWh) at 10" WC. (2.49 KPa) Manifold press

Min. Input: 16,000 Btu/hr (4.69KWh) at 6.4" WC. (1.60 KPa) Manifold press.

Max supply press: 11.0"WC (2.74 KPa) Min press: 10.4"WC (2.59 KPa)

C-14537

MAINTENANCE AND SERVICE

Conversion Kit Installation:

1. Turn the unit off by pressing the ON/OFF Key on the remote and shut off gas supply at the shut-off valve upstream of the unit. **CAUTION:** The gas supply must be shut off prior to disconnecting the electrical power and before proceeding with the conversion. Allow the valve and unit to cool down to room temperature.
2. Remove the glass door as shown in the MAINTENANCE AND SERVICE - GLASS DOOR REMOVAL.
3. Carefully remove the glass media, glass tray, and pilot shield.
4. Remove the burner as shown in the MAINTENANCE AND SERVICE - BURNER REMOVAL.
5. Convert the pilot injector (see Figure 22):
 - a) Using a $\frac{7}{16}$ " wrench, loosen the pilot head counter clockwise and fully remove
 - b) Remove the existing orifice and replace with the one supplied in the kit (see Figure 22)
 - c) Re-install the pilot head and tighten until it is back in the proper position (see Figure 23)
6. Convert the burner orifice:
 - a) Remove the main burner orifice with a $\frac{1}{2}$ " deep socket
 - b) Replace the NG orifice with the LP orifice. Do not over-tighten. The LP orifice hole will always be smaller than the NG hole.
7. Convert the SIT gas valve:
 - a) Use a T-20 driver to remove the two screws that hold the stepper regulator to the gas valve and disconnect the wire harness from the IFC.
 - b) Remove the rubber regulator diaphragm that is situated between the stepper regulator and the valve body. The new stepper regulator already has this diaphragm installed.
 - c) Install the LP stepper regulator, with the new longer T-20 screws included in the kit and connect the harness to the IFC.
8. Reinstall the burner, pilot shield, glass tray, glass media, and glass door. Refer to SECONDARY INSTALLATION - GLASS MEDIA INSTALLATION in your Owner's Manual. When re-installing the burner, ensure that the burner to pilot hood and shield relationship is similar to what is shown in Figure 23.
9. Reconnect the main gas line if it was disconnected and open the shut-off valve at the gas line to the unit.
10. Reconnect the electrical power to the unit.
11. Use a small brush to apply a warm soapy water solution to all gas connections (use a half dish soap and half warm water). If a gas leak is present, bubbling will occur. Gas leaks can be repaired by using an approved pipe thread sealant or approved Teflon tape. **NEVER USE AN OPEN FLAME WHEN TESTING FOR LEAKS.**
12. Relight the pilot and confirm the flame properly covers the flame sensor (see Figure 23). Should the pilot require adjustment, turn the adjustment screw (figure 36, page 33) clockwise to decrease or counterclockwise to increase until the correct flame is achieved.



Figure 22. Pilot Orifice

MAINTENANCE AND SERVICE

13. Relight the main burner in both the "HI" and "LO" positions to verify proper burner ignition, operation and proper flame appearance. Confirm the inlet and manifold pressures are within the acceptable ranges as directed in section INITIAL INTALLATION - GAS LINE CONNECTION AND TESTING. If the Q2GI has been installed at an altitude higher than 2000ft (610m) it is required to de-rate the unit accordingly:

In the USA: The appliance may be installed at higher altitudes. Please refer to your American Gas Association guidelines which state: the sea level rated input of Gas Designed Appliances installed at elevations above 2000 (610 m) feet is to be reduced 4% for each 1000 feet (305 m) above sea level. Refer also to local authorities or codes which have jurisdiction in your area regarding the de-rate guidelines.

In Canada: When the appliance is installed at elevations above 4500 feet (1372 m), the certified high altitude rating shall be reduced at the rate of 4% for each additional 1000 feet (305 m).

14. MAKE SURE that the conversion label is installed on or close to the rating label to signify that the unit has been converted to a different fuel type.



**Figure 23. Correct Burner & Pilot Shield Placement
(Q1 IPI model shown but similar to Q2 IPI model)**

INITIAL INSTALLATION

QUALIFIED INSTALLERS ONLY

INTRODUCTION:

This section of the owner's manual is for the use of qualified technicians only. Fireplace placement, hearths, facing, mantels, and venting terminations will be covered, as well as the gas and electric systems. There are several installation safety guidelines that must be adhered to. Please carefully read the safety precautions at the front of this manual.

NOTE: **The Q2G models can ONLY be run as a top vent;** the rear vent is only available for the Q2L models.

CAUTION: Clearances must be sufficient to allow access for maintenance and service.

PLACEMENT AND FRAMING:

NOTE: When framing the unit, care must be taken to consider the final floor thickness, the bottom of the fireplace must sit flush with the finished floor to ensure proper fit of the surround components.

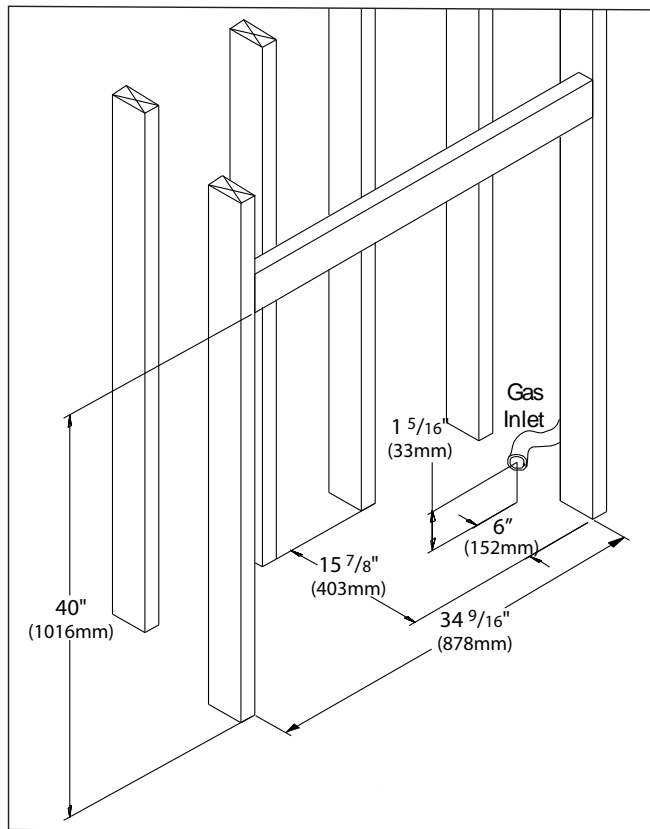

Figure 24. Dimensions for Framing the Firebox

The location for the fireplace can be along a wall, raised, at floor level, or in a corner. There are specific framing measurements for each situation. The basic opening should have the dimensions shown in Figure 17. The fireplace must have a strong and level surface to be placed on. The surface should be made of wood or a non-combustible material, not carpet.

The gas line, **3/8" JIC fitting**, should be brought to the right side of the fireplace. The location should be chosen so the fireplace will be at least **36 inches (914 mm)** from drapes, doors and other combustibles. The framed opening should also be a minimum of **4 5/8" (117 mm)** from the nearest perpendicular wall (sidewall to the edge of the opening).

Minimum Framing Dimensions		
Depth	15 ⁷ / ₈ "	403mm
Width	34 ⁹ / ₁₆ "	878mm
Header Height	40"	1016mm
Chase Height (Rear Vent)	N/A	N/A
Chase Height (Top Vent)	*54"	1372mm
Gas Inlet (Front)	6"	152mm
Gas Inlet (Height)	1 ⁵ / ₁₆ "	33mm

*Minimum dimension with only an elbow off the top. Any vertical rise added increase the chase height respectively.

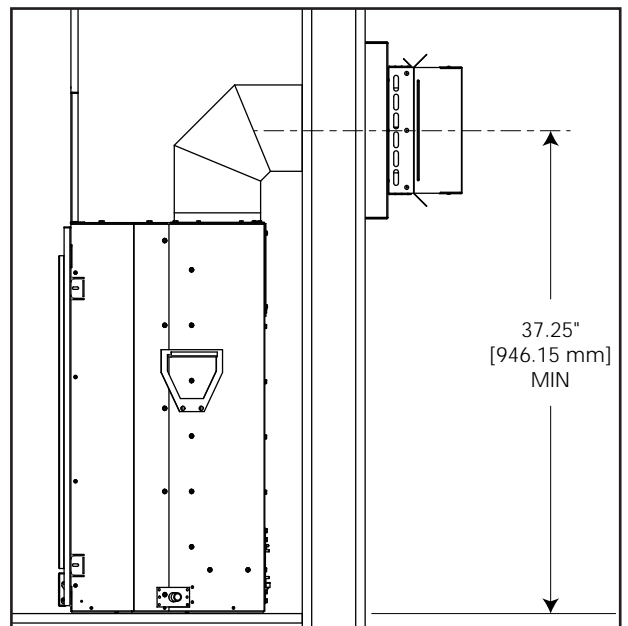

INITIAL INSTALLATION

QUALIFIED INSTALLERS ONLY

FRAMING PLATE INSTALLATION:

A steel framing plate is included with your Q2GI / Q2GID. The plate does not come installed on the unit but it attaches very easily with a 1/4" hex driver as shown below. This plate is used as a supportive surface to fill in the air gap above the unit in the installation construction. Non combustible material can be placed over this plate such a cement board. Non combustible material is only necessary over the fireplace opening and does not need to span the entire width of the framing plate. A wood mantle can be placed over top of the non-combustible as long as it stays within the mantle specifications.

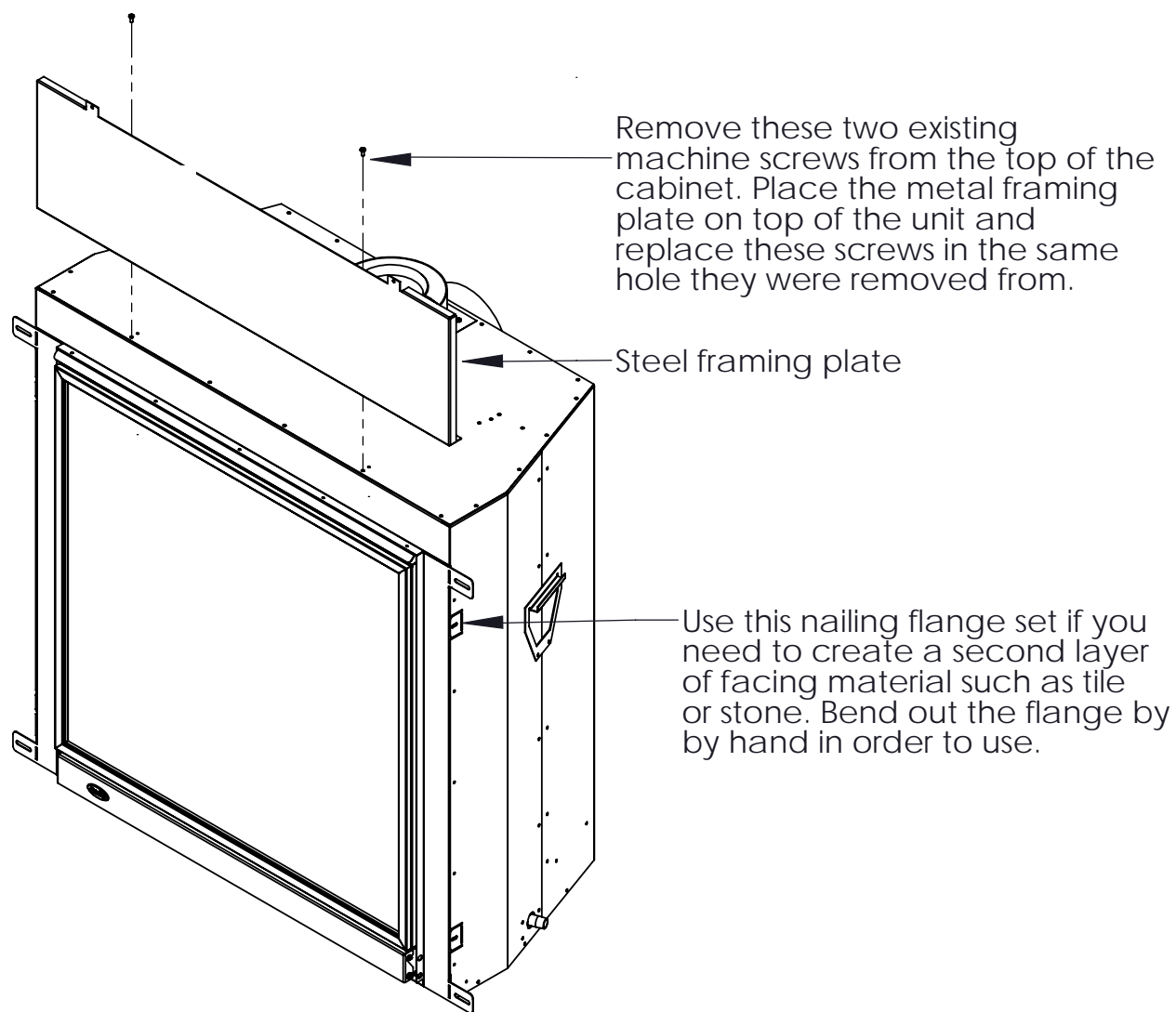

Figure 25. Framing Plate Installation

INITIAL INSTALLATION

QUALIFIED INSTALLERS ONLY

MANTLE & NON-COMBUSTIBLE CLEARANCES:

When installing the Q2GI / Q2GID as a zero clearance fireplace the correct clearances and materials must be used:

ABOVE UNIT: A minimum **10" (254mm)** of non-combustible facing material must be used above the firebox opening (in front of the included steel framing plate). The non-combustible is only required directly over the firebox opening and does not need to span the entire width of the framing plate.

IN FRONT OF UNIT: The Q2GI / Q2GID can be placed on the floor if desired although it is recommended that it be raised at least an inch or higher for more heat sensitive materials such as carpet or linoleum.

ADJACENT/SIDEWALL: There must be a minimum distance of **4 5/8" (117mm)** from the side of the Q2GI / Q2GID cabinet to an adjacent wall composed of combustible material.

MANTLE: It is not necessary to install a mantle, but if one is desired the guidelines as shown in Figure 27. Side mantle clearance should be no less than the distance from the top of the unit to the bottom on the top portion of the mantle.

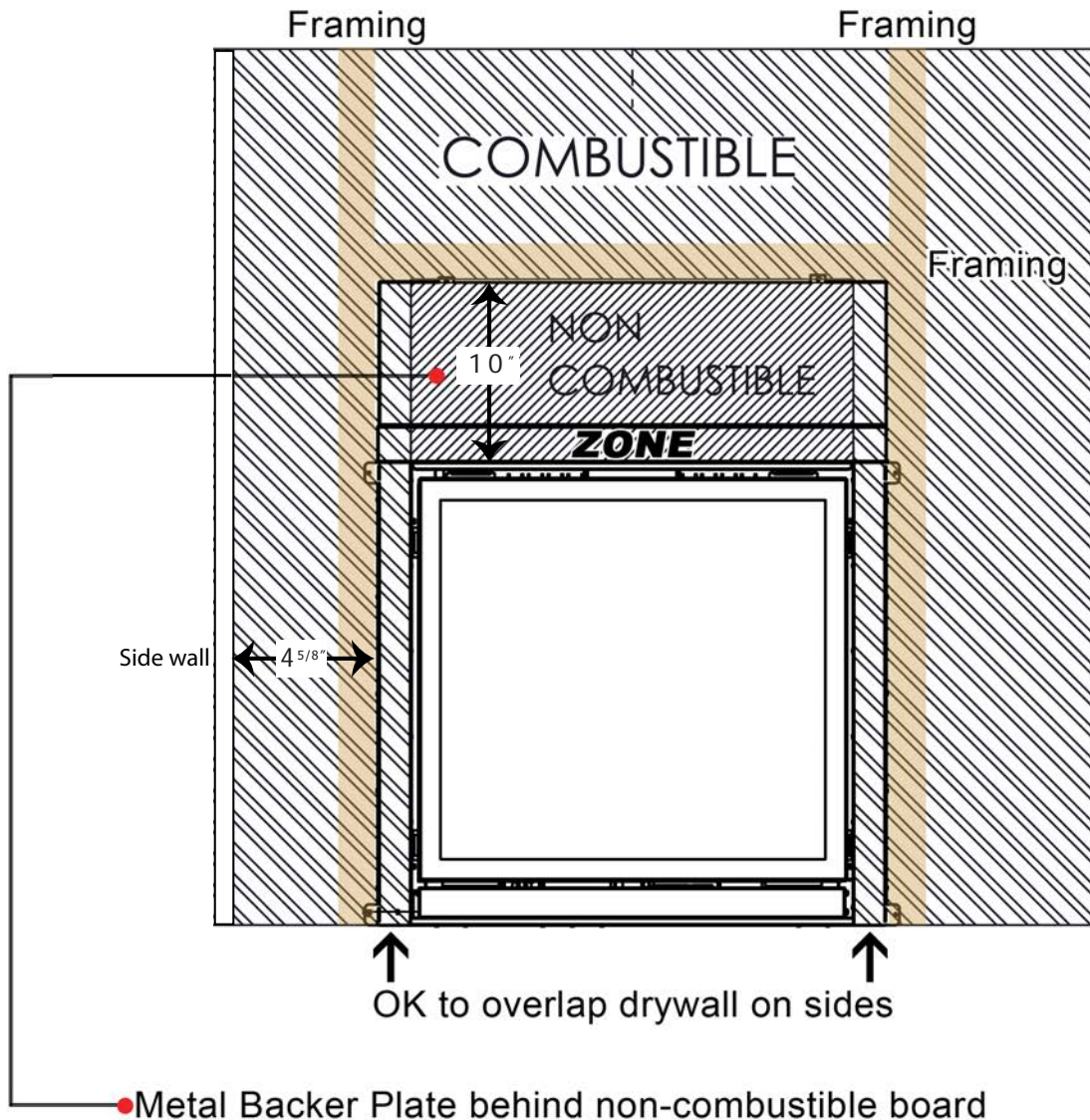

Figure 26. Non Combustible Material

INITIAL INSTALLATION

QUALIFIED INSTALLERS ONLY

Minimum Mantle Clearances

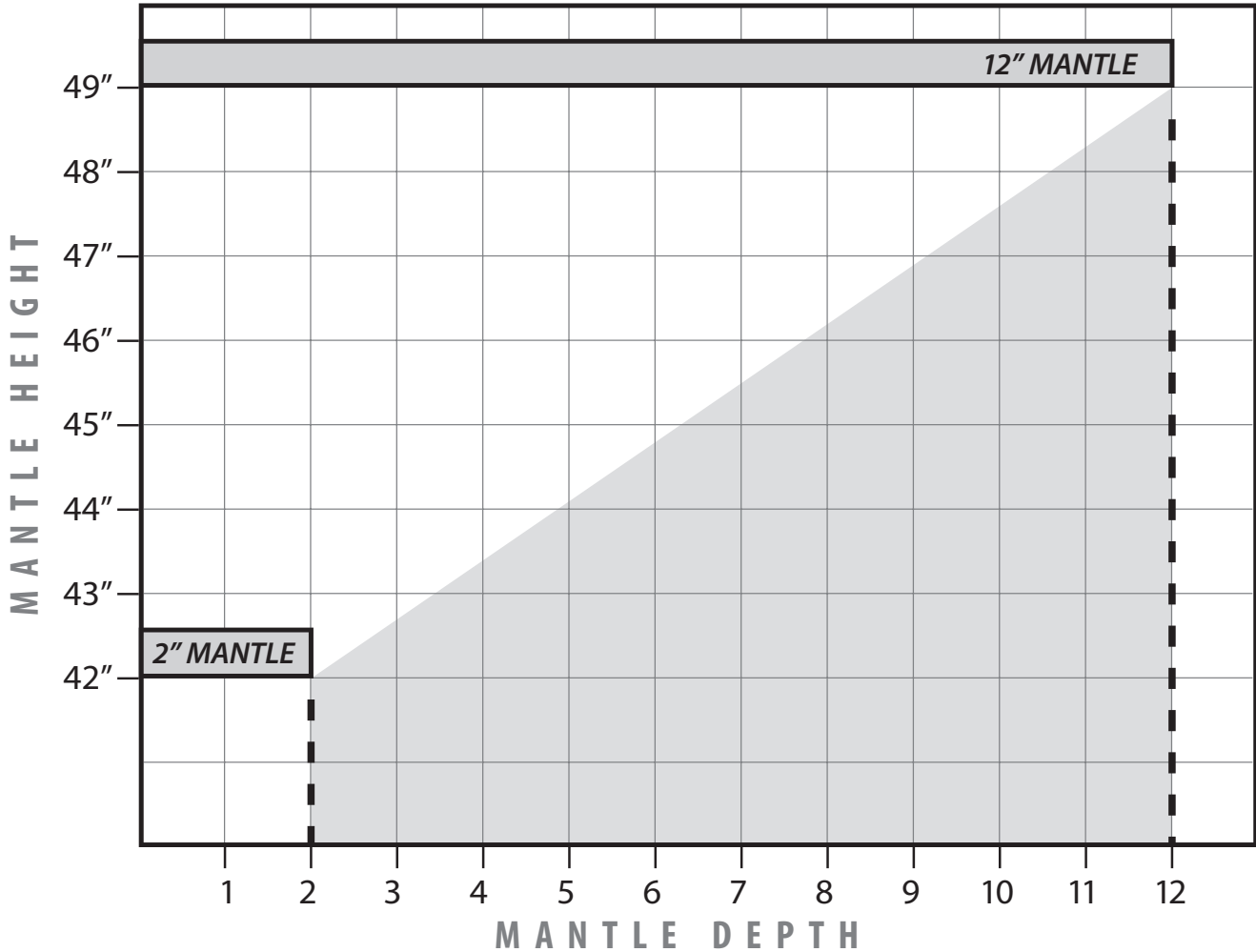

Figure 27. Mantle Clearances

Note: Mantle height dimensions are based from the bottom of the appliance.

INITIAL INSTALLATION

QUALIFIED INSTALLERS ONLY

CORNER INSTALLATION:

The dimensions for installing a fireplace in the corner of a room are given in Figures 27. Refer to "INITIAL INSTALLATION - ALLOWABLE CO-AXIAL VENT CONFIGURATIONS" for allowable pipe lengths.

Do not interfere with the structural integrity of the walls.

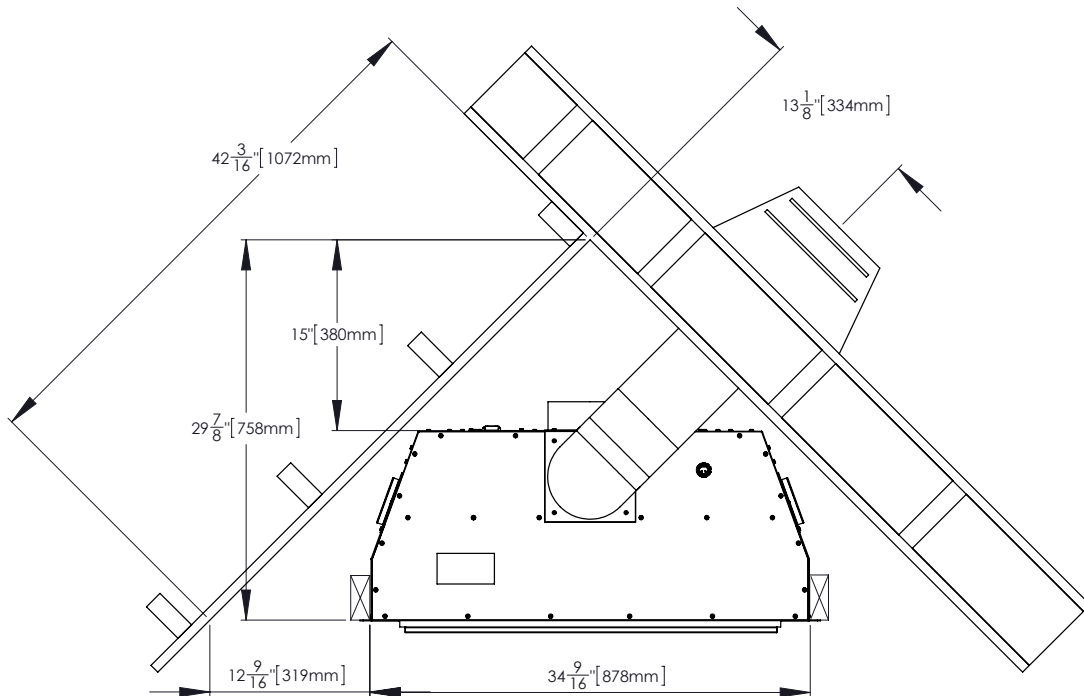

Figure 28. Dimensions for a corner installation

DIRECT VENT:

WARNING: This appliance has been designed to draw room air for proper heat circulation from the bottom of the unit, and out the top front. Blocking or modifying these openings in any way can create hazardous situations.

The vent length for the Q2GI / Q2GID must be between **6" (150 mm)** and **40' (12.2 m)**. This model is vented with co-axial **4"** intake, **6 5/8"** exhaust aluminum or stainless steel approved rigid vent leading into a vertical or horizontal termination cap. This model can also be used with aluminum or stainless steel flex venting. The flue collar of this model will fit inside of a standard **4" x 6 5/8"** vent and must be either correctly interlocked or fastened, with three screws directly to the vent collar.

Check periodically that the vents are unrestricted. Also ensure that all direct vent pipes have been properly sealed and installed after routine inspection or cleaning. The air intake and exhaust pipes must be installed in the correct locations on the top of the Q2GI / Q2GID.

INITIAL INSTALLATION

QUALIFIED INSTALLERS ONLY

VENT TERMINATION RESTRICTIONS:

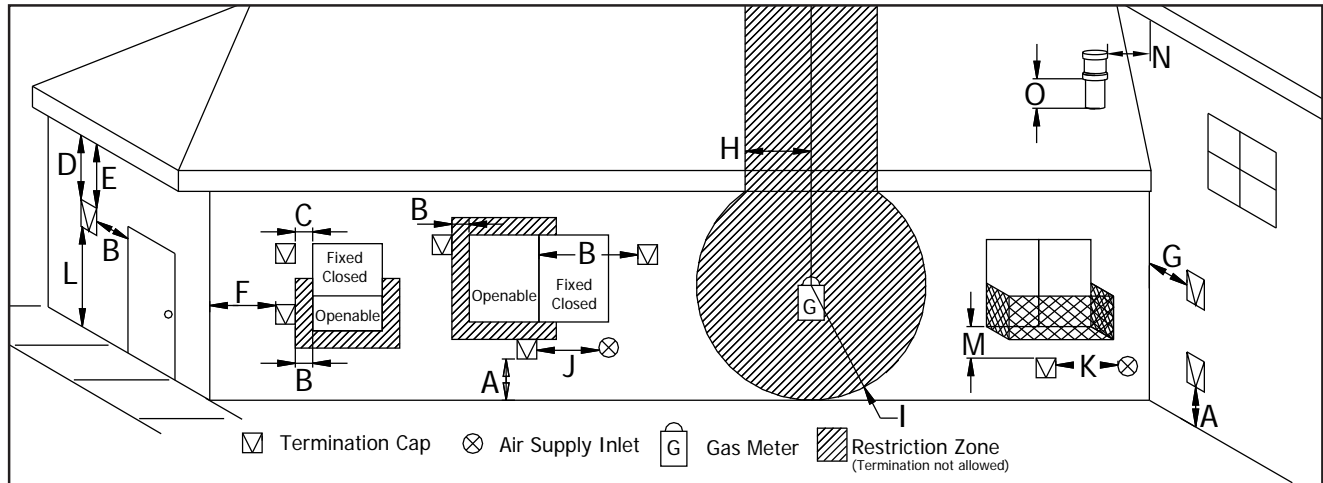

Figure 29. Vent Termination Restrictions, refer to Table 3

Table 3: Vent Termination Clearances

Letter	Canadian Installation ¹	US Installation ²	Description
A		12 in (30 cm)	Clearance above grade, verandah, porch, deck, or balcony.
B	12 in (30 cm)	9 in (23 cm)	Clearance from window or door that may be opened.
C		12 in (30 cm)*	Clearance from permanently closed window (to prevent condensation).
D		24 in (60 cm)*	Vertical clearance to ventilated soffit located above the terminal, within a horizontal distance of 2 ft (60 cm) from center line of terminal.
E		18 in (45 cm)*	Clearance to unventilated soffit.
F		12 in (30 cm)*	Clearance to outside corner.
G		12 in (30 cm)*	Clearance to inside corner.
H	3 ft (91 cm) within a height of 15 ft (4.5 m) above the meter/regulator assembly	3 ft (91 cm) within a height of 15 ft (4.5 m) above the meter/regulator assembly*	Clearance to each side of center line extended above meter/regulator assembly.
I		3 ft (91 cm)*	Radial clearance around service regulator vent outlet.
J		9 in (23 cm)	Clearance to non-mechanical air supply inlet to building, or the combustion air inlet to any other appliance.
K		3 ft (91 cm) above if within 10 ft (3 m) horizontally	Clearance to mechanical air supply inlet.
L		7 ft (2.13 m) [†]	Clearance above paved sidewalk or paved driveway located on public property.
M		12 in / 30 cm ⁺	Clearance under verandah, porch, deck, or balcony.
N		12 in (30 cm)*	Clearance horizontally to any surface (such as an exterior wall) for vertical terminations.
O		12 in (30 cm)	Clearance above roof line for vertical terminations.

¹ In accordance with the current CSA B149, Natural Gas and Propane Installation Code.

² In accordance with the current ANSI Z223.1 NFPA 54, National Fuel Gas Code.

* These numbers are only estimates.

[†] A vent shall not terminate directly above a side walk or paved driveway that is located between two single family dwellings and it serves both dwellings.

⁺ Permitted only if verandah, porch, deck, or balcony is fully open on a minimum of two sides beneath the floor.

Clearances are in accordance with local installation codes and the requirements of the gas supplier.

NOTE: Venting terminals shall not be recessed into walls or siding.

INITIAL INSTALLATION

QUALIFIED INSTALLERS ONLY

VENTING CLEARANCES:

A **1" (25 mm)** clearance to combustibles must be maintained around any vertical vent pipe. Around a horizontal vent pipe, the clearance to combustibles should be **2" (51 mm)** above and **1½" (38 mm)** on the sides and bottom. When combustible materials are directly above a 90° elbow, **14" (356 mm)** of clearance are necessary.

Table 4. Vent Pipe Minimum Clearances

	Vertical Pipe to the Side Walls	Horizontal Pipe to the Sides & Bottom	Above First Elbow	Above Subsequent Elbows	Above Horizontal Vent Pipe	Wall Frame 8" (203mm) or less
Hard Pipe	1" (25.4 mm)	1½" (38 mm)	14" (356 mm)	3" (76.2 mm)	2" (51 mm)	10"x10" (25x25cm)

A **10" (254 mm) x 10" (254 mm)** frame (see Figure 29) will assure the proper support and spacing for the vent pipe as it passes through the wall. Installations in Canada require that a wall thimble be used for passing through walls and ceilings. All sealing and vapour barriers must comply with local building codes.

The configuration of the venting pipes depends on the locations of walls, ceilings, and studs. However, the pipes cannot be of arbitrary length and arrangement. Because the length of the vertical and horizontal sections dramatically affects the burning efficiency of the fireplace, certain guidelines have been set in INITIAL INSTALLATION - ALLOWABLE CO-AXIAL VENT CONFIGURATIONS. Venting terminals can not be recessed into a wall or siding.

WARNING: This gas appliance must not be connected to a chimney flue serving a separate solid-burning appliances.

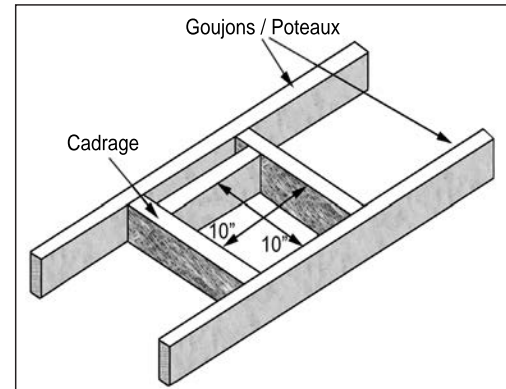

Figure 29. Vent Framing For Wall or Ceiling

APPROVED VENTING PARTS:

This fireplace has been tested and certified for use with the venting brand names listed in table 5. Refer to table 6 for part numbers of commonly used parts for both venting systems. For more venting parts please visit the respective manufacturers' website.

WARNING: Do not mix parts from different vent manufacturers' systems.

Table 5: Approved Vent Manufacturers

Manufacturer	Brand Name	Nominal Sizes
ICC	EXCELDirect	4" x 6 5/8"
M&G Dura-Vent	Direct Vent Pro	4" x 6 5/8"
Selkirk	DIRECT-TEMP	4" x 6 5/8"
Selkirk	AMP DV	4" x 6 5/8"
Metal-Fab Inc.	Sure-Seal	4" x 6 1/2"*

EXCEPTION TO WARNING: This product has been evaluated by Intertek for using a DirectVent Pro starting collar in conjunction with venting brand names listed in table 6. Use of these systems with the DirectVent Pro starting collar is deemed acceptable and does not affect the Intertek listing of the appliance.

INITIAL INSTALLATION

QUALIFIED INSTALLERS ONLY

Table 6: Vent Part Numbers (must state if galvanized or black wanted)

M&G Duravent Direct Vent Pro	ICC EXCELDirect	Selkirk DIRECT-TEMP	Amerivent AMV DV	Metal-Fab Sure-Seal DV*	Description
46DVA-06	4DL6	4DT-06		4D6	6" pipe length
			4D7		7" pipe length
46DVA-09	4DL9	4DT-09			9" pipe length
46DVA-12	4DL1	4DT-12	4D12	4D12	12" pipe length
46DVA-18		4DT-18		4D18	18" pipe length
46DVA-24	4DL2	4DT-24	4D2	4D24	24" pipe length
46DVA-36	4DL3	4DT-36	4D3	4D36	36" pipe length
46DVA-48	4DL4	4DT-48	4D4	4D48	48" pipe length
46DVA-60					60" pipe length
46DVA-E30					30° elbow
46DVA-E45	4DE45	4DT-EL45	4D45L	4D45L	45° elbow
46DVA-E90	4DE90	4DT-EL90	4D90L	4D90A, 4D90L	90° elbow
46DVA-VSS, DVA-BVS	VSS	4DT-VS/VSK	4DHVS, DVSK	4DVS	Vinyl siding standoff/sheild
46DVA-WT, 46DVA-WTU	4WT	4DT-WT	4DWT	4DWT, 4DWT11	Wall thimble
46DVA-SC	SQSC, SC	4DT-SC	4DSC	4DSC	Storm collar
46DVA-WFS		4DT-FS		4DFSH	Wall Fire stop
46DVA-FS	4CS	4DT-FS	4DFSP	4DFS, 4DSPFS	Ceiling Fire stop
46DVA-IS	4AS	4DT-AIS	4DAIS12, AIS36	4DIS	Attic Insulation Shield
46DVA-WS	4WS	4DT-WS/B	4DWS	4DWS	Wall strap/support/band
46DVA-VCH	4SVT			4DVT	High wind vertical termination
46DVA-HC	4HT	4DT-HC	4DHCS	4DHT	High wind horizontal termination
46DVA-WG	4HTS		4DHWS	8DVTS	Horizontal Wind / Heat Guard
46DVA-VWG	4SVTS				Vertical Wind Guard
				5DAL	3" to 10" pipe, adjustable
46DVA-17TA					11" to 17" pipe, adjustable
46DVA-24TA					17" to 24" pipe, adjustable
	4DLA30				16.5" to 29" pipe , adjustable
	4DLS1				1 7/8" to 9" slip length pipe
	4DLS2				1 7/8" to 21" slip length pipe
46DVA-F6	6EFA	4DT-AF6	4DF	5DF	Flashing, 0/12 to 6/12 roof pitch
46DVA-F12	6EFB	4DT-AF12	4DF12	5DF-12	Flashing, 7/12 to 12/12 roof pitch
46DVA-FF	6EF			5DFT	Flat Roof Flashings
46DVA-CFK	4MF				Masonry Flashing
46DVA-KCA	4CA6	4DT-CCKA	4DRCKA		Chimney Conversion Kit A [USA only]
46DVA-KCB	4CA7	4DT-CCKB			Chimney Conversion Kit B [USA only]
46DVA-KCC	4CA8				Chimney Conversion Kit C [USA only]

*** When using Metal-Fab Sure Seal a Duravent Appliance Adaptor, part #4DDA, is required**

INITIAL INSTALLATION

QUALIFIED INSTALLERS ONLY

ALLOWABLE CO-AXIAL VENT CONFIGURATIONS:

Figure 30 shows the range of venting options for **top vented configurations only** using either vertical or horizontal terminations; any layout that remains within the shaded area is acceptable. Having the fewest number of elbows is ideal as they tend to disrupt air movement. Using 45° elbows is preferable to using 90° elbows. Also, a shorter vent system will perform better than a longer one. The total length of horizontal vent pipe can not exceed 20 feet (6.1m) and the total vent length can not exceed 40ft (12.2m).

Any combination of rise and run can be used as long as it lays within the shaded area (a total of three (3) 90° elbows or six (6) 45° elbows can be used. In addition to what is shown, if a 90° elbow is used in the horizontal plane, 3 feet (91.4cm) must be subtracted from the allowable horizontal run (for each 45° elbow, 1½ feet must be subtracted).

High wind guard required for all vertical vent runs with no horizontal run.
ICC EXCELDirect TM-SVTS
M&G Duravent Pro 46DVA-VWG

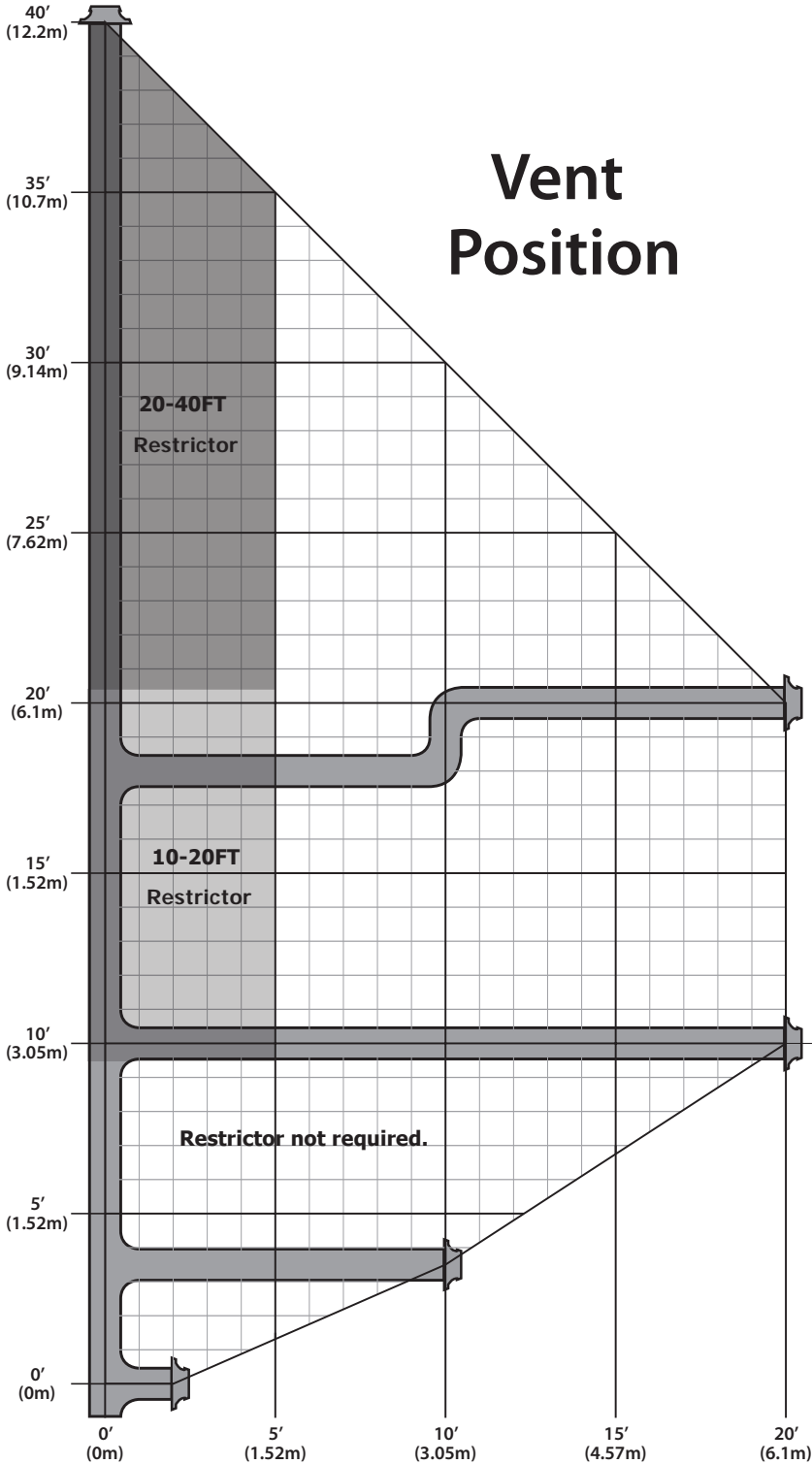

**Vertical vent height does not account for elbows

Figure 30. Possible Vent Configurations for Top Vent Only. Vertical and Horizontal Terminations

INITIAL INSTALLATION

QUALIFIED INSTALLERS ONLY

FLEX VENTING:

This fireplace is certified to work with aluminium co-axial flex venting. Flex venting can be used in the same configurations as rigid pipe, see venting diagram for details. Flex venting is only to be used for the run, it must be adapted to rigid piping for exterior wall penetration and termination. **Note: Adhere to all rigid venting safety measures and clearances.**

Use 4X7 Flex Adapter Kit [50-3788]: This kit will allow you to adapt co-axial flex to the fireplace, make your vent run, then adapt back to rigid venting (**flex not included**).

Any 4X7 CSA or UL flue gas certified aluminum or stainless steel flex is acceptable. Proper spacers must be used to keep pipes from contacting each other. Proper venting spacers must be used, nothing makeshift. Examples of allowable flex pipe brands include, but are not limited to the following:

- M&G Duravent
- Selkirk Corp
- ICC
- Z-Flex
- Flexmaster
- Chim Flex
- Olympia
- BDM
- Metal-Fab

Only the flex venting and spacers are needed. You must use the flex adapter kit and a certified rigid pipe termination cap.

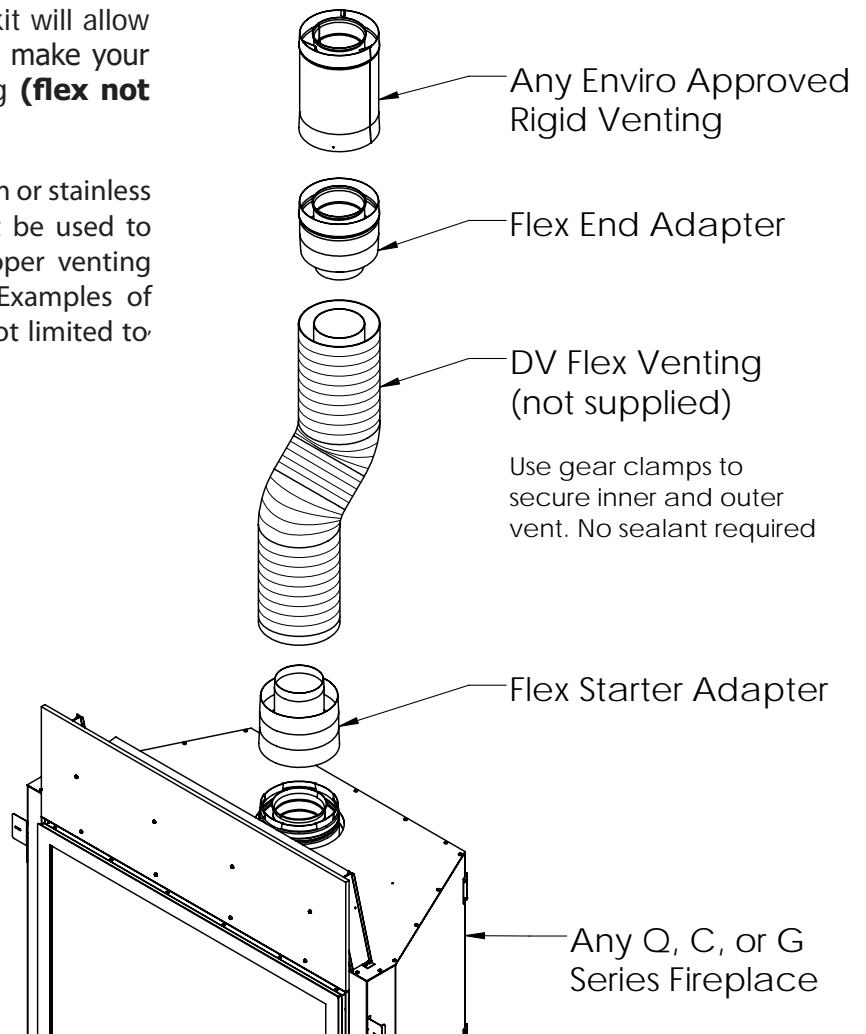

Figure 27. Flex Adapter Kit Install

INSTALLATION NOTES:

- Do not bend flex vent over 90 degrees.
- All horizontal runs should have a minimum 1/4" (6mm) rise per foot for optimal performance.
- Do not allow the inner flex pipe to contact the outer pipe, keep it pulled tight and use spacer springs.
- Spacers are required at the start, middle, and end of each elbow to ensure gap is maintained.
- Do not add any extensions to the preset kits, if more length is required, use rigid pipe.
- No need for liquid sealant; secure flex venting with aluminum vent tape and apply sufficient self-tapping screws.

INITIAL INSTALLATION

QUALIFIED INSTALLERS ONLY

HORIZONTAL TERMINATION:

NOTES:

1. Horizontal pipes must not be level. For every 12" (305 mm) of horizontal travel (away from the stove), there should be at least 1/4" (6.4 mm) of vertical travel. Never allow the vent to run downward, as this could cause high temperatures or even present the possibility of a fire.

2. The exterior of the horizontal vent termination must not be blocked or obstructed.

3. If the vent termination is not being attached to wood, the four wood screws provided should be replaced with material appropriate fasteners.

4. For buildings with vinyl siding, a vinyl standoff should be installed between the vent cap and the exterior wall. Attach the vinyl siding standoff to the horizontal termination. Note that the termination bolts onto the flat portion of the standoff, providing an air space between the wall and the vent termination. The air gap prevents excessive heat from possibly melting the vinyl siding.

5. Horizontal pipes must be supported every **3' (914 mm)**.

Plumber's all round strap will suffice.

6. Ensure venting clearances are maintained, see Page 26 for details.

Step 1. Set the fireplace in the desired location. Check to determine if wall studs will be in the way when the venting system is attached. If this is the case, the location of the fireplace may have to be adjusted or the venting may have to be offset.

Step 2. Direct vent pipe sections are designed with special twist-lock connections. Dry fit the desired combination of pipe and elbows to the appliance adaptor.

Step 3. With the pipe in the correct position and attached to the fireplace, mark the wall for a **10" (25.4 cm) x 10" (25.4 cm)** square hole (see Figure 31). The center of the hole should match the center line of the horizontal pipe. Cut and frame the hole in the exterior wall where the vent will be terminated. If the wall being penetrated is made of a non-combustible material (i.e. masonry or concrete) a **7" (17.8 cm)** hole is acceptable.

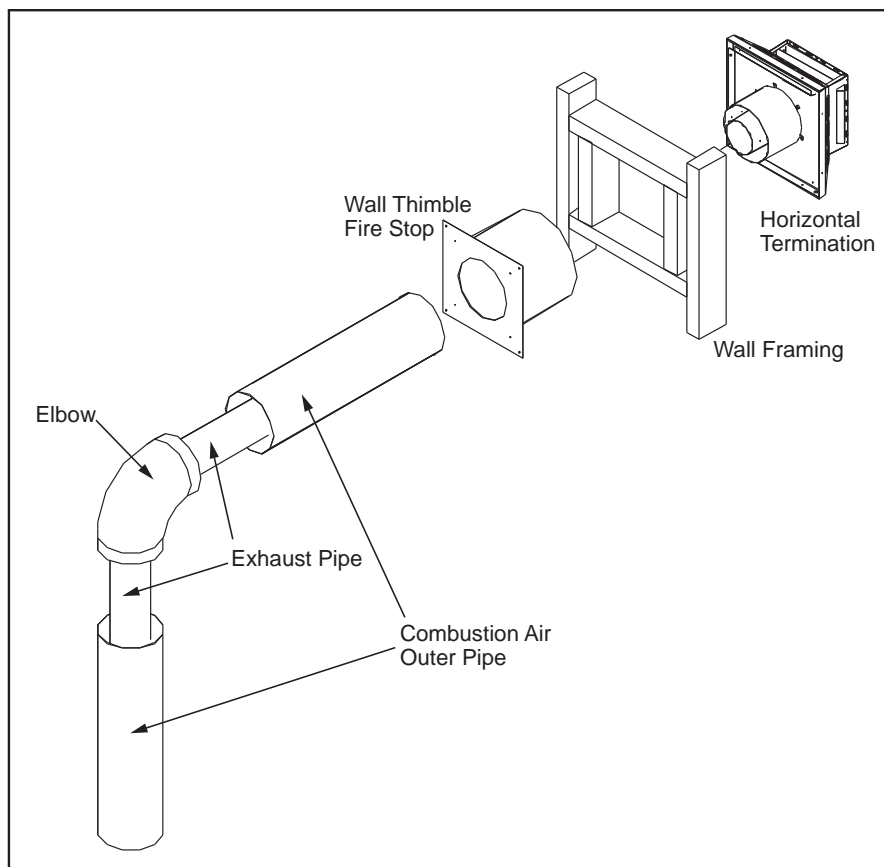

Figure 31. Horizontal Vent Termination

INITIAL INSTALLATION

QUALIFIED INSTALLERS ONLY

NOTE: For Simpson Duravent only, place a bead of Mil-Pac or Rutland No 78 Stove and Gasket Cement on the outer edge of the inner exhaust pipe (non-flared end). Push the pipe sections together, then twist about ¼ turn, making sure the two sections are fully locked. Wrap all seams with foil ducting tape.

Step 4. With the hole now framed, the wall thimble installed, and the pipe extending into the wall, proceed to the outside. Attach the termination to the pipe using RTV and Mil-Pac or Rutland No 78 Stove and Gasket Cement to seal joints. The vent pipe must extend into the vent cap at least **1¼ inches (3.2 cm)**. Secure the connection between the vent cap and the pipe by attaching the two (2) sheet metal straps, which extend from the vent cap assembly to the outer wall of the vent pipe. Bend any remaining portion of the strap back towards the vent cap. Security Secure Vent uses a twist lock cap.

Step 5. Position the horizontal vent termination in the center of the **10" (25.4 cm)** square hole and attach to the exterior wall with the four screws provided. The arrow on the vent termination should be pointing up. Run a bead of non-hardening mastic around the edges of the vent cap, to make a seal with the wall. Ensure the proper clearances to combustibles have been maintained.

VERTICAL TERMINATION:

Step 1. Check the instructions for required clearances (air spaces) to combustibles when passing through ceilings, walls, roofs, enclosures, attic rafters, or other nearby combustible surfaces. Do not pack air spaces with insulation.

Step 2. Set the gas appliance in the desired location. Drop a plumb bob down from the ceiling to the position of the appliance flue exit, and mark the location where the vent will penetrate the ceiling. Drill a small hole at this point. Next, drop a plumb bob from the roof to the hole previously drilled in the ceiling, mark the spot where the vent will penetrate the roof. Determine if ceiling joists, roof rafters, or other framing will obstruct the venting system. You may wish to relocate the appliance, or to offset, to avoid cutting load bearing members.

Step 3. To install the Round Support Box/Wall Thimble in a flat ceiling, cut a **10" (25.4 cm)** square hole in the ceiling, centered in the hole drilled in Step 2. Frame the hole as shown in Figure 32.

Step 4. Assemble the desired lengths of black pipe and elbows necessary to reach from the appliance adapter up through the Round Support Box. Insure that all pipe and elbow connections are in their fully twist-locked position.

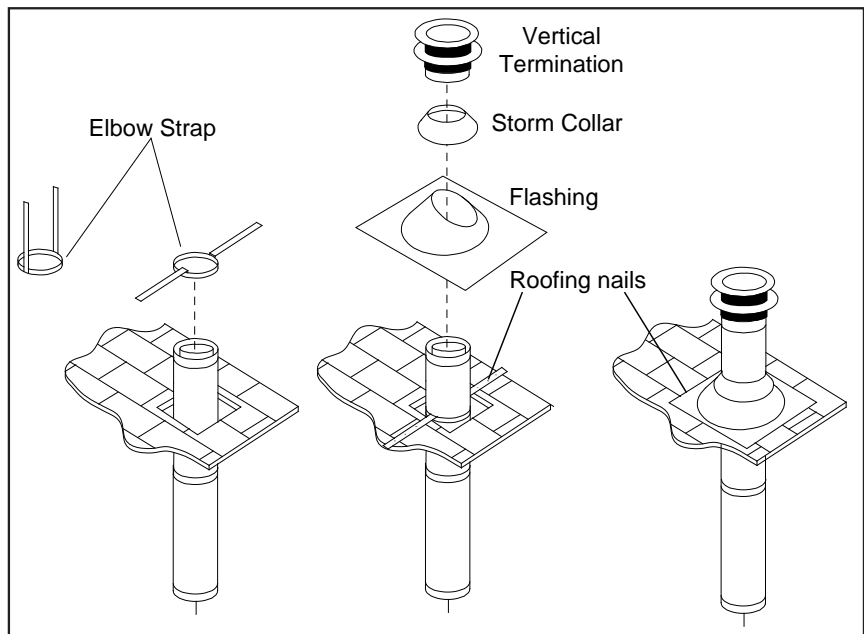

Figure 32. Vertical Vent Termination

INITIAL INSTALLATION

QUALIFIED INSTALLERS ONLY

- Step 5.** Cut hole in the roof centered on the small hole placed in the roof from Step 2. The hole should be of sufficient size to meet minimum requirements for Clearance to Combustibles, as specified. Continue to assemble lengths of pipe and elbows necessary to reach from the ceiling support box up through the roof line. Galvanized pipe and elbows may be utilized in the attic, as well as above the roof line. The galvanized finish is desirable above the roof line, due to the higher corrosion resistance.
- Step 6.** Once the pipe sections have been joined, and run up through the hole in the roof, slip an elbow strap over the exposed sections, bend the support straps outwards, and push the elbow strap down to the roof level, as shown in Figure 32. Tighten the clamp around the pipe section. Use a level to make sure the pipe is truly vertical. With roofing nails, secure the support straps to the roof. Seal the nails holes heads with non-hardening mastic. Trim the excess length of the support straps that extend out beyond the edge of the flashing.
- Step 7.** Slip the flashing over the pipe section protruding through the roof. Secure the base of the flashing to the roof with roofing nails. Use a non-hardening sealant between the uphill edge of the flashing and the roof. Insure the roofing material overlaps the top edge of the flashing. Verify that you have at least the minimum clearance to combustibles at the roof line.
- Step 8.** Continue to add pipe sections until the height of the vent cap meets the minimum code requirements. Refer to Figure 33 and Table 7. Note that for steep roof pitches, the vent height must be increased. In high wind conditions, nearby trees, adjoining roof lines, steep pitched roofs, and other similar factors can result in poor draft, or down drafting. In these cases, increasing the vent height may solve the problem.
- Step 9.** Slip the storm collar over the pipe, and push it down to the top of the roof flashing as shown in Figure 32. Use the non-hardening sealant around the joint between the pipe and the storm collar.
- Step 10.** Twist-lock the vent cap.

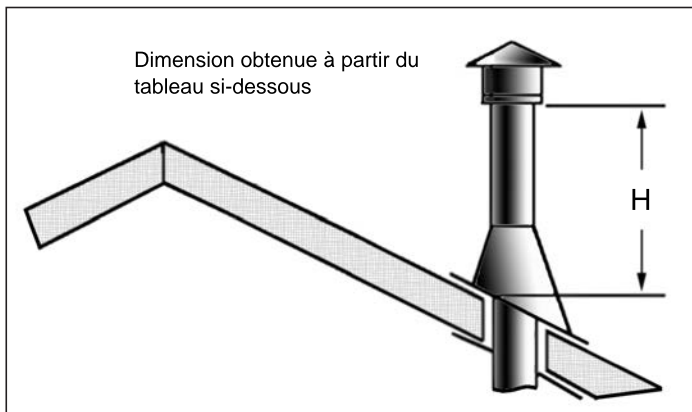

Figure 33: Height of Vertical Termination; Reference Table 7

Table 7: Minimum 'H' for Figure 33.

Roof Pitch	Minimum Height (H)	
	Feet	Meters
Flat to 7/12	1	0.3
Over 7/12 to 8/12	1.5	0.46
Over 8/12 to 9/12	2	0.61
Over 9/12 to 10/12	2.5	0.76
Over 10/12 to 11/12	3.25	0.99
Over 11/12 to 12/12	4	1.22
Over 12/12 to 14/12	5	1.52
Over 14/12 to 16/12	6	1.83
Over 16/12 to 18/12	7	2.13
Over 18/12 to 20/12	7.5	2.29
Over 20/12 to 21/12	8	2.44

INITIAL INSTALLATION

QUALIFIED INSTALLERS ONLY

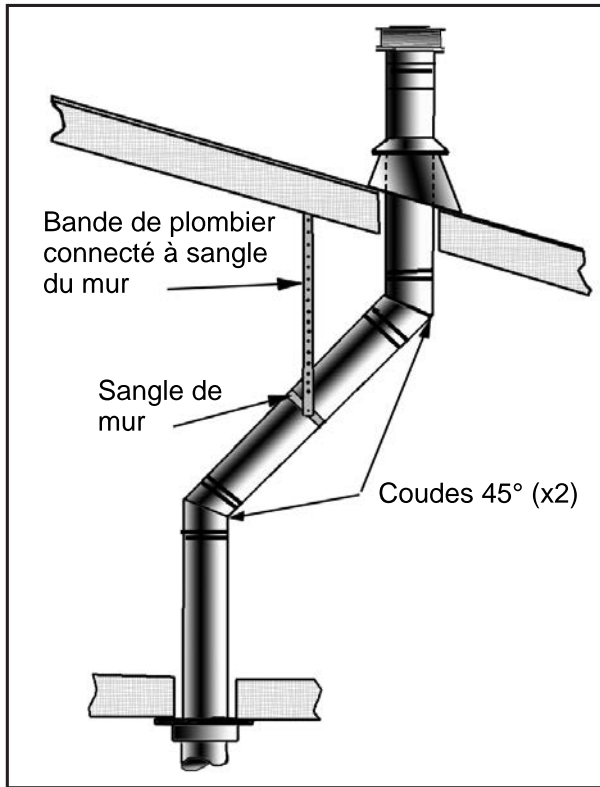

Figure 34: Use of Wall Straps.

NOTES:

- (1) If an offset is necessary in the attic to avoid obstructions, it is important to support the vent pipe every **3' (914 mm)**, to avoid excessive stress on the elbows, and possible separation. Wall straps are available for this purpose (see Figure 34).
- (2) When ever possible, use 45° degree elbows instead of 90° degree elbows. The 45° degree elbow offers less restriction to the flow of flue gases and intake air.
- (3) For multi story installations; a ceiling firestop is required at the second floor, and any subsequent floors (see Figure 28). The opening should be framed to **10" (254 mm) x 10" (254 mm)** inside dimensions, in the same manner as shown in Figure 35.

- (4) Any occupied areas above the first floor, including closets and storage spaces, which the vertical vent passes through, must be enclosed. The enclosure may be framed and sheet-rocked with standard building materials. However consult the appliance manufactures installation instructions for the minimum allowable clearance between the outside of the vent pipe, and the combustible surfaces of the enclosure. Do not fill any required air spaces with insulation.

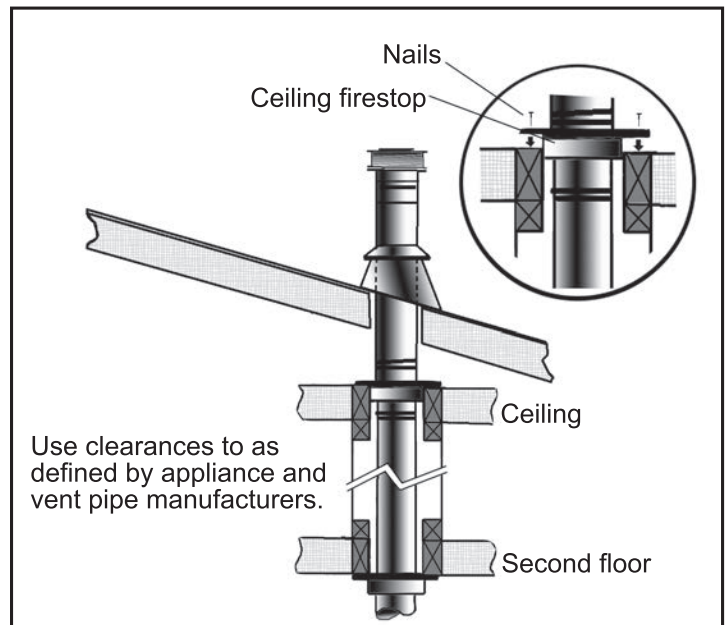

Figure 35: Multi-Story Vent Pipe Installation

INITIAL INSTALLATION

QUALIFIED INSTALLERS ONLY

GAS LINE CONNECTION AND TESTING:

WARNING: Only persons licensed to work with gas piping may make the necessary gas connections to this appliance.

GAS LINE CONNECTION

- This stove is equipped with a certified flexible pipe located on the left side of the unit terminating in a **3/8"** female JIC fitting. Consult your local authorities codes or the CAN/CGA B 149 (1 or 2) installation code in Canada, or in the USA gas installations follow either local codes or the current edition of the National Fuel Gas Code ANSI Z223.1.
- The efficiency rating of this appliance is a product thermal efficiency rating determined under continuous operating conditions and was determined independently of any installed system.

The appliance and its shutoff valves must be disconnected from the gas supply piping system during any pressure testing where the pressure exceeds 1/2 PSIG (3.45 KPa) or damage will occur to the valve.

The appliance must be isolated from the gas supply piping system by closing its individual manual shutoff valve during any pressure testing of the gas supply piping system at test pressures equal to or less than 1/2 psig (3.45 KPa).

Always check for gas leaks with a soap and water solution after completing the required pressure test.

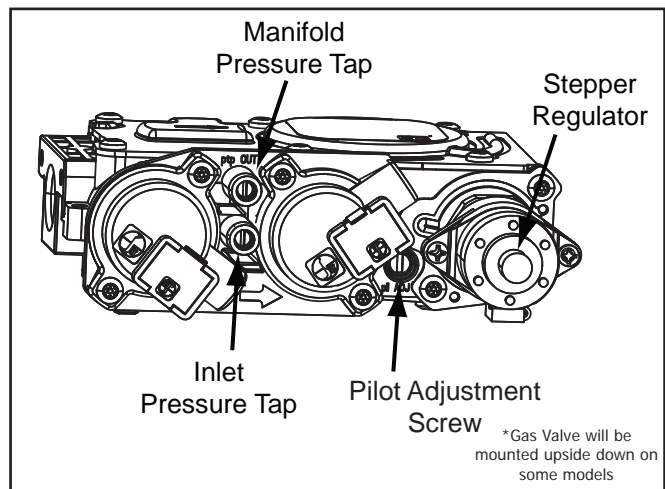

Figure 36: Fully Labeled Gas Valve.
See Dexen User Manual for Q2LID valve details

TO TEST VALVE PRESSURES

The pressure taps are located on the top right of the valve shown in Figure 36.

- Turn set screw 1 turn counter clockwise to loosen,
- Place 5/16" (8 mm) I.D. hose over pressure tap system.
- Check pressures using a manometer.
- When finished, release pressure, remove hose & tighten set screw.

Table 8: Pressure and BTU Information

	Natural Gas	Propane
Main Orifice	#40 DMS	#55 DMS
Manifold Pressure	3.5" W.C. (0.87 KPa)	10.0" W.C. (2.49 KPa)
Min. Manifold Pressure	1.6" W.C. (0.40 KPa)	6.4" W.C. (1.59 KPa)
Max Supply Pressure	7.0" W.C. (1.74 KPa)	11.0" W.C. (2.74 KPa)
Min. Supply Pressure	4.5" W.C. (1.12 KPa)	10.4" W.C. (2.59 KPa)
Max BTU/hr Input	24,000 BTU/hr (7.03 KW)	20,000 BTU/hr (5.86 KW)
Min. BTU/hr Input	17,000 BTU/hr (1.12 KW)	16,000 BTU/hr (4.69 KW)

NEVER USE AN OPEN FLAME FOR LEAK TESTING.

INITIAL INSTALLATION

QUALIFIED INSTALLERS ONLY

ELECTRICAL REQUIREMENTS:

The fireplace must be electrically connected and grounded in accordance with local codes or, in the absence of local codes, with the current CSA C22.1 Canadian Electrical Code Part 1, Safety Standards For Electrical Installations, or The National Electrical Code ANSI / NFPA 70 in the US.

WARNING: The electrical grounding instructions must be followed. The unit is equipped with a three-prong (grounding) plug for your protection against shock hazard, and should be plugged directly into a properly grounded three-prong outlet. DO NOT cut or remove the grounding prong from this plug.

CAUTION: When servicing controls, label all wires prior to disconnection. Wiring errors can cause improper and dangerous operation. Verify proper operation after servicing.

If any of the original wire as supplied with the appliance must be replaced, it must be replaced with 18 AWG wire with a temperature rating of 105°C

Note: For Q2GID specific wiring diagram refer to the Dexen user manual supplied and label attached to the fireplace.

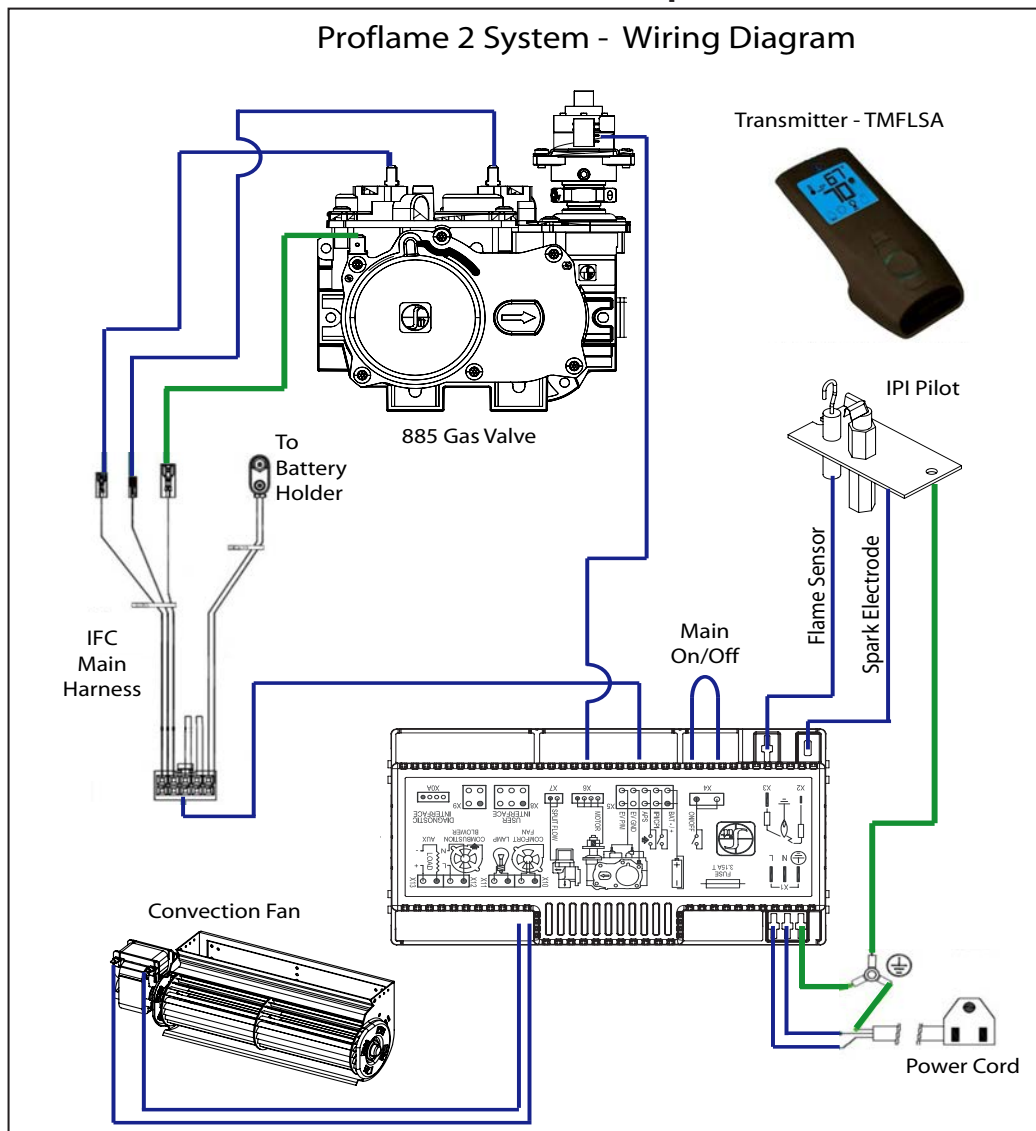

Figure 37: Wiring Diagram

SECONDARY INSTALLATION

GLASS MEDIA INSTALLATION (50-2937):

Caution! Always wear gloves when handling glass media; some pieces may be sharp.

A 4 lb bag of glass media is included with the Q2. Open the bag carefully and spread it out evenly over the enameled tray and burner. Do not pour the entire bag contents out, use just enough glass to cover the tray and burner with a single layer (as shown below). The rest of the glass should be kept for replacement if needed. If too much glass is used the flame appearance could be compromised or soot build-up may occur. The large open holes in the burner pan are used to supply fresh air to the flame but the glass will sit over these holes. It is perfectly acceptable should a few pieces fall through upon installation.

NOTE - Make sure the pilot flame is un-obstructed and has a clear path the burner. Keep the pilot area clear of any glass media.



Figure 38. Glass Media Installation

OPTIONAL CLEAR GLASS MEDIA SHOWN FOR CLARITY

OPTIONAL DRIFTWOOD LOG SET INSTALLATION (50-3314):

This kit can be installed with the glass media included with the unit or with the Vermiculite included with the Driftwood kit. The media of choice will be installed first, see figure 39. Make sure a thin even layer of media is installed over the area shown. Once media is installed place the logs and rocks around the burner as shown in the installation instructions. For more detailed setup information refer to the setup guide included with the Driftwood Log Set.



Figure 39. Driftwood Log Set Installation

TROUBLE SHOOTING

DIAGNOSTIC FLASH CODES (DOES NOT APPLY TO Q2GID MODELS):

1. Fail to ignite: If there is no positive ignition, the board will go into lock out and the LED will blink 3 times in intervals until the system is reset.
2. Low battery condition (<4V): the LED indicator will blink one (1) time in intervals.
3. Parasitic Pilot Flame: the LED indicator will blink two (2) times in intervals.
4. System Lock out: the LED indicator will blink three (3) times in intervals.

Additional Ignition Information

1. The Proflame2 IFC will try two (2) times for ignition.
2. Each try for ignition will last approximately 60 seconds.
3. The wait time between the two tries is approximately 35 seconds.

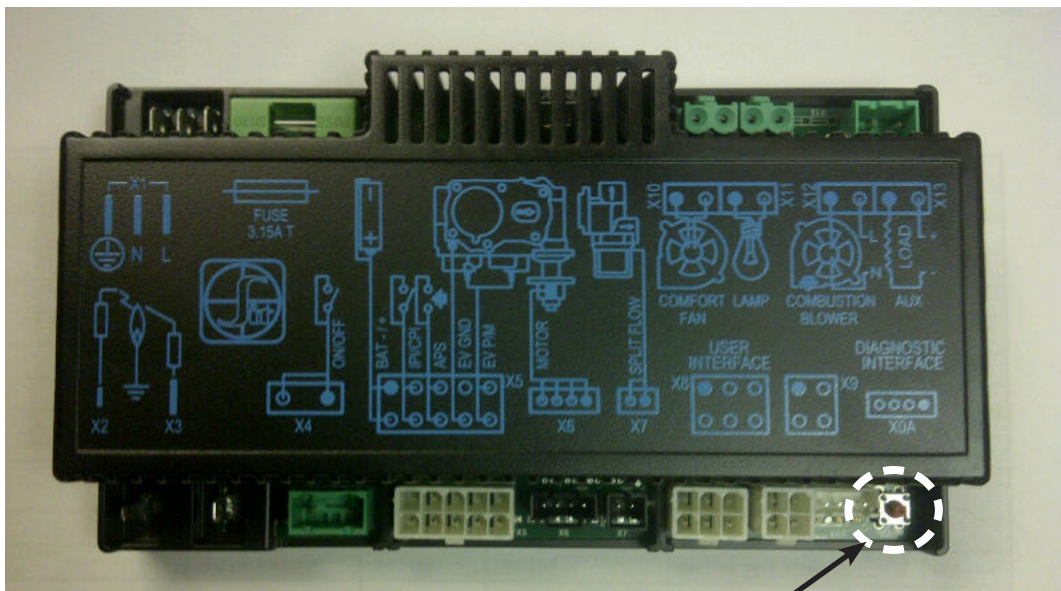

LED Location

Figure 40: IFC LED Location

TROUBLE SHOOTING

Note: For Q2GID specific troubleshooting refer to the Dexen user manual supplied

Problem	Possible Cause	Solution
Thermostat does not work	The pilot flame has gone out	· Turn it ON
	The On/Off switch is turn to OFF	
	The thermostat is set too high	· Set the thermostat to a lower temperature
No spark generation	Spark develops near the pilot assembly or could occur onboard	· Check pilot assembly wiring
		· Check for broken or poor connection from the sparker to the electrode
		· Check for the spark shorting or arcing at other locations
		· Check for defective sparker and spark electrode
No pilot flame ignition	No spark from the igniter	· See "no spark generation"
	Air in the gas line	· It takes a while for all the air to purge out of the pilot before gas can reach the pilot and ignite
	Pilot gas pressure dropout upon main burner gas valve opening	· Check gas mains supply and pressure
	No gas flow out of the pilot burner	· Check gas valve wirings and connections to the board
		· Check the pilot burner for obstruction
Pilot will not remain lit	Problem with Flame Sensor circuit	· Check for proper connection of the Flame Sensor to the IFC board
		· Check pilot for full flame impingement around Flame Sensor
		· If flame is too small, check gas pressure, adjust pilot rate screw, check pilot head for damage
	· Ensure the ground wire is properly attached to the pilot mounting bracket and that it makes a good electrical connection.	
	Restrictor setting	· Use the correct restrictor setting for the venting configuration
Remote control does not work	The pilot light has gone out	· See "Pilot will not remain lit"
	The remote is too far away from the heater	· Use the remote closer to the heater
	One of the remote control batteries are dead	· Replace the batteries
No reaction to command	IFC or transmitter batteries are low	· Replace the batteries
	A maximum number of failed ignitions or flame restorations have been reached.	· Remove any possible blocking conditions. See "locking conditions"
		· See how to reset the board from Lockout
	No communication between the remote control and the IFC	· Reprogram the transmitter to the IFC. · Follow the initializing system for the first time

PARTS LIST

Note: For Q2GID specific troubleshooting refer to the Dexen user manual supplied

Table 10: Q2GI Parts List

Reference Number	Part Description	Part Number
1	Q2GI / Q2GID Owner's Manual	50-3058
2	Black Enameled Steel Liner Set (3 Pieces)	50-2978
3	120 Degree Fan Temperature Sensor	EC-001
4	Q2 Safety Screen and Frame	50-3971
5	Door Complete	50-3049
6	Diamond Glass Media - Black (1 lb) *4lbs required*	50-3850
7	Q2 Burner Pan	50-3046
8	Q2 Enameled Glass Tray	50-3407
9	S.I.T. 885 Valve w/ NG Stepper Motor	50-2682
-	Pilot Assembly Gasket	EC-021
10	Proflame 2 Transmitter (GTMFL) - Hand Held	50-3265
-	Proflame 2 Transmitter (GTMFL) - Wall Mount	50-3028
11	Enviro Gel Decal	50-322
12	Control Cover w/ Decal	50-3022
13	Battery Holder 4 x AA	50-3027
14	Proflame 2 Integrated Fireplace Control (IFC)	50-3791
-	Proflame 2 IFC Wire Harness (0.584.924)	50-3030
15	Door Release Tool	50-2510
16	Domestic Power Cord (115v)	EC-042
17	Convection Fan only	50-2493
-	Convection Fan w/ Mount	50-3836
18	Electrical Box Strain Relief	50-3019
19	Electrical Box	50-3018
20	PSE IPI Pilot Asesmbly (2021)	50-4058
-	IPI LP Pilot Orifice (2021)	50-4080
-	12 oz. Can of Metallic Black Touch Up Paint	PAINT-12-MB
-	12 oz. Can of Flat Black Touch Up Paint	PAINT-12-FB
-	Door Glass w/ Gasket (28.5 x 23.8in)	50-3021

PARTS DIAGRAM

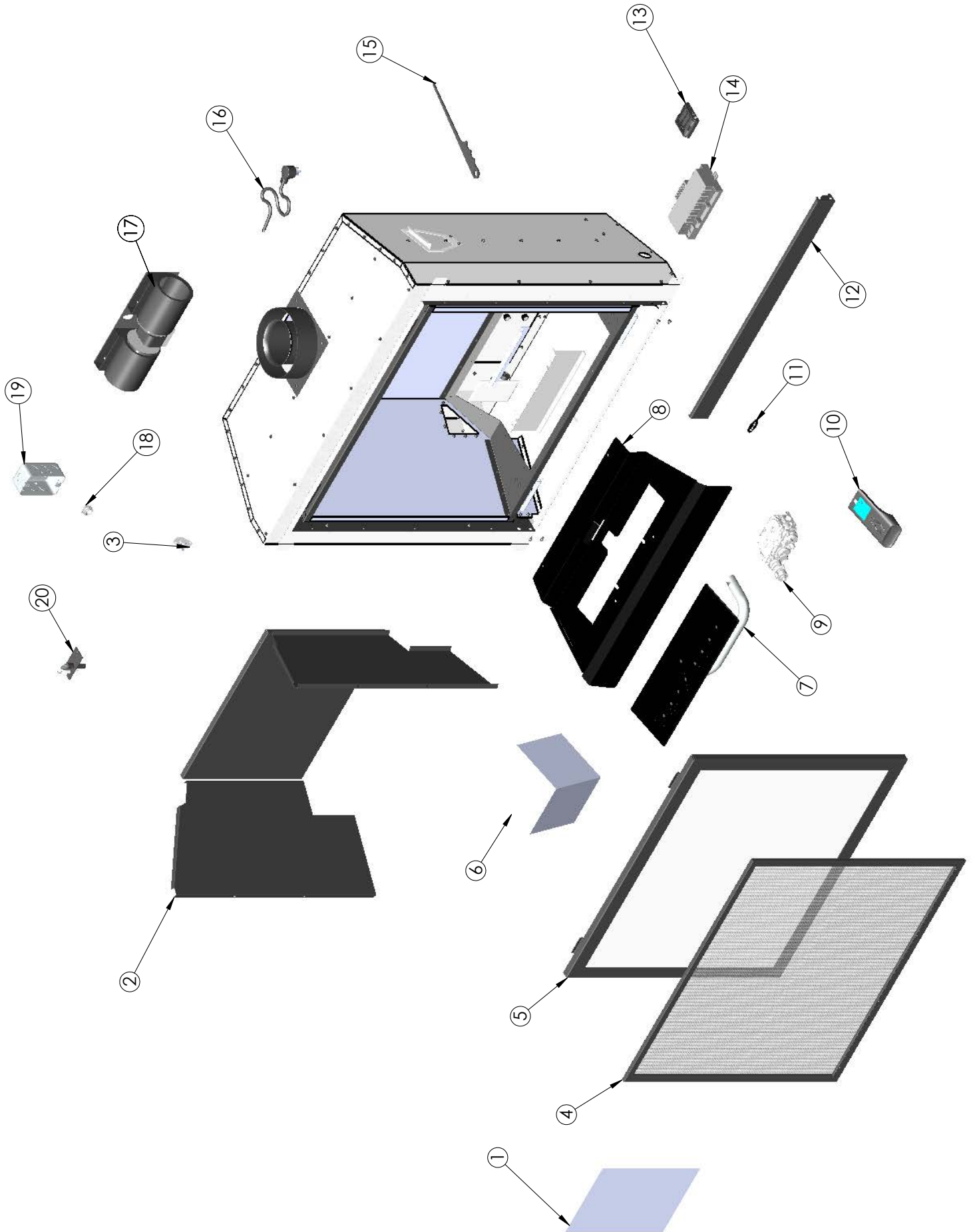

NOTES

NOTES



Warranty for Enviro Gas Products

Sherwood Industries Ltd. ("Sherwood") hereby warrants, subject to the terms and conditions herein set forth, this product against defects in material and workmanship during the specified warranty period starting from the date of original purchase at retail. In the event of a defect of material or workmanship during the specified warranty period, Sherwood reserves the right to make repairs or to assess the replacement of a defective product at Sherwood's factory. The shipping costs are to be paid by the consumer. All warranties by Sherwood are set forth herein and no claim shall be made against Sherwood on any oral warranty or representation.

Conditions

- A completed warranty registration must be submitted to Sherwood within 90 days of original purchase via the online warranty registration page or via the mail-in warranty registration card provided. Have the installer fill in the installation data sheet in the back of the manual for warranty and future reference.
- This warranty applies only to the original owner in the original location from date of install.
- The unit must have been properly installed by a qualified technician or installer, and must meet all local and national building code requirements.
- The warranty does not cover removal and re-installation costs.
- Sherwood Industries Ltd. reserves the right to make changes without notice.
- Sherwood Industries Ltd. and its employees or representatives will not assume any damages, either directly or indirectly caused by improper usage, operation, installation, servicing or maintenance of this appliance.
- A proof of original purchase must be provided by you or the dealer including serial number.
- This warranty does not cover any discoloration of the safety screen mesh.

Exclusions

An expanded list of exclusions is available at www.enviro.com/help/warranty.html

This warranty does not cover:

- Damage as a result of improper usage or abuse.
- Damage caused from over-firing due to incorrect setup or tampering.
- Damage caused by incorrect installation.

To the Dealer

- Provide name, address and telephone number of purchaser and date of purchase.
- Provide date of purchase. Name of installer and dealer. Serial number of the appliance. Nature of complaint, defects or malfunction, description and part # of any parts replaced.
- Pictures or return of damaged or defective product may be required.

To the Distributor

- Sign and verify that work and information are correct.

Sherwood Industries Ltd.

6782 Oldfield Road, Victoria, BC . Canada V8M 2A3
 Online warranty registration: www.enviro.com/warranty/

Category	One Year	Two Year	Limited Lifetime (7yr)
Parts ^{1,2} (unit serial number required)		✓	
Firebox Liner Panels ³		✓	
Firebox			✓
Heat Exchanger			✓
Burner			✓
Ceramic Logs ⁴			✓
Ceramic Glass ⁵	✓		
Pedestal / Legs (excluding finish)			✓
Door Assembly			✓
Surround Panels (excluding finish)			✓
Exterior Panels (excluding finish)			Up to 5 years
Electrical Components		✓	
Exterior Surface Finishing	✓		
Labour	✓		

¹ Whereas warranty has expired, replacement parts will be warrantied for 90 days from part purchase date. Labour not included. Unit serial number required.

² 50-173 Westport Fan Kit covered for up to 5 years from purchase date. Labour not included. Unit serial required.

³ Excluding damage to the finish caused by improper setup of the appliance, or color changes.

⁴ Log set and panels excludes wear and tear or breakage caused by cleaning or service.

⁵ Glass is covered for thermal breakage. Photos of box, inside of door, and unit serial # must be supplied for breakage due to shipping.

⁶ Exterior Surface finishing covers plating, enamel or paint and excludes colour changes, chipping, and fingerprints. Travel costs not included.

INSTALLATION DATA SHEET

The following information must be recorded by the installer for warranty purposes and future reference.

NAME OF OWNER:

ADDRESS:

PHONE: _____

NAME OF DEALER:

ADDRESS:

PHONE: _____

MODEL: _____
SERIAL NUMBER: _____
DATE OF PURCHASE: _____ (dd/mm/yyyy)
DATE OF INSTALLATION: _____ (dd/mm/yyyy)

 NATURAL GAS (NAT) PROPANE (LPG)

INLET GAS PRESSURE: _____ in wc
MAIN BURNER ORIFICE: _____ # DMS
PILOT ORIFICE # _____ OR _____ in diam.

INSTALLER'S SIGNATURE:

NAME OF INSTALLER:

ADDRESS:

PHONE: _____