

IMPORTANT:
THESE INSTRUCTIONS ARE TO
REMAIN WITH THE HOMEOWNER
SAVE THESE INSTRUCTIONS



SERIAL #

SAFETY NOTICE

If this stove is not properly installed, a house fire may result. For your safety, follow the installation instructions. Contact local building or fire officials about restrictions and installation inspection requirements in your area.

INSTALLATION AND OPERATING INSTRUCTIONS

Meets the US Environmental Protection Agency's 2020 Particulate Emission Standards.



**MODEL:
VISTA INSERT LE**



Visit www.pacificenergy.net for the most recent version of this manual

Table of Contents

Contents

Table of Contents	2	Maintenance Checks	10
Rating Label	3	Baffle Removal	11
Safety	4	Dimensions	12
Chimney Smoke and Creosote Formation.....	4	Surround Dimensions	12
Chimney Fires	4	Minimum Fireplace Dimensions	13
To Avoid a Chimney Fire	5	Hearth Requirements:.....	13
In Case of a Chimney Fire.....	5	Ember Protection:.....	14
Curing of the Paint Finish.....	5	Optional Leveling Legs	14
Disposal of Ashes	5	Clearances	15
Operation	6	Minimum Clearances to Combustibles.....	15
Wood Selection.....	6	Installation	16
DO NOT BURN :	6	Into a Masonry Fireplace	16
How to Test Your Wood	6	Combustion Air	19
Lighting a fire	7	Into a Factory Built Fireplace	19
Normal Operation	7	Blowers	20
Convection Blower Operation.....	8	Blower Service/Replace.....	20
Restarting After Extended or Overnight Burns	8	Surround Assembly and Installation	21
Proper Draft	8	Troubleshooting	22
Ash Removal.....	8	Firebrick Installation	23
Maintenance	9	Firebrick Installation.....	24
Door Gaskets -	9	Replacement Parts	26
Door Glass -	9		

WARNING

**HOT GLASS WILL CAUSE
BURNS.**

**DO NOT TOUCH GLASS UNTIL
COOLED.**

**NEVER ALLOW CHILDREN TO
TOUCH GLASS.**

STATE of CALIFORNIA

WARNING: this product can expose you to chemicals including ceramic fibers, which are known to the state of California to cause cancer, and to carbon monoxide, which is known to the state of California to cause birth defects or other reproductive harm.

For more information go to www.p65warnings.ca.gov.

**This warning is applicable to all
PACIFIC ENERGY FIREPLACE PRODUCTS**

PLEASE SAVE THESE INSTRUCTIONS

This manual describes the installation and operation of the Pacific Energy, VISTA INSERT LE; Fireplace Insert wood heater. Please read this entire manual before you install and use your new room heater. Failure to follow instructions may result in property damage, bodily injury, or even death.

NOTE: WE STRONGLY RECOMMEND THAT SMOKE AND CARBON MONOXIDE DETECTORS BE INSTALLED IN THE AREA WHERE THE HEATER IS TO BE INSTALLED.

If smoke detectors have been previously installed, you may notice that they are operating more frequently. This may be due to curing of stove paint or fumes caused by accidentally leaving the fire door open. Do not disconnect the detectors.

SAFETY NOTICE: If this stove is not properly installed, a house fire may result. For your safety, follow the installation instructions. Contact local building or fire officials about restrictions and installation inspection requirements in you area.

Rating Label

This heater meets the 2020 U.S. Environmental Protection Agency's crib wood emission limits for wood heaters sold after May 15, 2020 using Method 28R. Under specific test conditions this heater has been shown to deliver heat at rates ranging from 13,500 to 23,200 Btu/hr.

MODEL / MODÈLE: VISTA INSERT LE
LISTED SOLID WOOD FUEL FIREPLACE INSERT / APPAREIL DU TYPE INSERTION DE COMBUSTIBLE SOLIDE DE CHEMINÉE
CERTIFIED FOR USE IN CANADA AND U.S.A.
CERTIFIÉ POUR: ULCS628-93 (R2016)/ UL1482 (2011)
 Refer to Intertek's Directory of Building Products for detailed information



MINIMUM CLEARANCE TO COMBUSTIBLES (MEASURED FROM SIDE OF DOOR)
DÉGAGEMENT MINIMUM AUX COMBUSTIBLES (MESURÉ DU CÔTE DE LA PORTE)

A) ADJACENT SIDEWALL / PAROI LATÉRALE ADJACENTE **330 MM / 13 IN**
 B) SIDE FACING / REVÊTEMENT LATÉRAL **240 MM / 9.5 IN**

MEASURED FROM INSERT TOP / MESURÉ À PARTIR D'INSERT

C) TOP FACING / REVÊTEMENT SUPÉRIEUR **330 MM / 13 IN**
 D) MANTEL / MANTEAU **330 MM / 13 IN**
 E) EMBER PROTECTION - FIRING SIDE / EPREUVE DU FEU, CANADA **457 MM / 18 IN**
 FIRING SIDE, U.S.A. **406 MM / 16 IN**
 F) EMBER PROTECTION - SIDES / AUTRES CÔTÉS. **200 MM / 8 IN**

INSTALL ONLY ON A NON-COMBUSTIBLE HEARTH UNDER THE UNIT, EXTENDING A DISTANCE OF 16IN / 406MM IN FRONT OF THE FIREPLACE OPENING FACE. // INSTALLER UNIQUEMENT SUR UN COEUR NON COMBUSTIBLE SOUS L'APPAREIL, S'ÉTENDANT À UNE DISTANCE DE 16po / 406mm DEVANT LE FACE D'OUVERTURE DU FOYER.

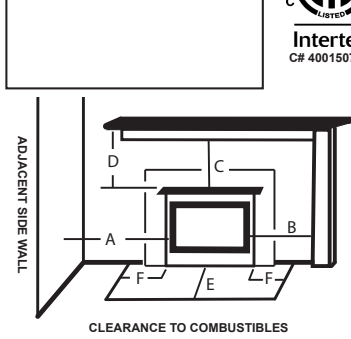

ADJACENT SIDE WALL

CLEARANCE TO COMBUSTIBLES

- INSTALL AND USE ONLY IN ACCORDANCE WITH PACIFIC ENERGY'S INSTALLATION AND OPERATING INSTRUCTIONS.
- CONTACT LOCAL BUILDING OR FIRE OFFICIALS ABOUT CODES, RESTRICTIONS AND INSTALLATION INSPECTION IN YOUR AREA.
- INSTALL AND USE ONLY IN MASONRY OR FACTORY BUILT FIREPLACE.
- DO NOT CONNECT THIS UNIT TO A CHIMNEY FLUE SERVING ANOTHER APPLIANCE.
- COMPONENTS REQUIRED FOR INSTALLATION : FULL FLUE LINER CONFORMING TO CAN/ULC-S635 OR CAN/ULC-S640. IN U.S.A. FLUE LINER CONFORMING TO UL-1777 OR DIRECT FLUE CONNECTION ASSEMBLY.
- ELECTRICAL RATING 115V, 60HZ, 1.2 AMP. ROUTE POWER CORD AWAY FROM UNIT.
- DANGER: RISK OF ELECTRICAL SHOCK. DISCONNECT POWER BEFORE SERVICING UNIT.
- FOR USE WITH SOLID FUEL (CORDWOOD) ONLY. BURNING OTHER MATERIALS MAY CAUSE DAMAGE TO STOVE OR HOME.
- DO NOT USE A GRATE OR ELEVATE FIRE - BUILD WOOD FIRE DIRECTLY ON HEARTH.
- OPERATE ONLY WITH FEED DOOR CLOSED. OPEN TO FEED FIRE ONLY. REPLACE GLASS ONLY WITH CERAMIC GLASS.
- INSPECT AND CLEAN CHIMNEY FREQUENTLY. UNDER CERTAIN CONDITIONS OF USE, CREOSOTE BUILDUP MAY OCCUR RAPIDLY.
- THIS WOOD HEATER NEEDS PERIODIC INSPECTION AND REPAIR FOR PROPER OPERATION.
- CONSULT THE OWNER'S MANUAL FOR FURTHER INFORMATION.
- IT IS AGAINST FEDERAL REGULATIONS TO OPERATE THIS WOOD HEATER IN A MANNER INCONSISTENT WITH THE OPERATING INSTRUCTIONS IN THE OWNER'S MANUAL

U.S. ENVIRONMENTAL PROTECTION AGENCY.
 Certified to comply with 2020 crib wood particulate emission standards, using test Method 28R.

1.9 g/hr

221019

MADE IN CANADA

MANUFACTURED BY:
 PACIFIC ENERGY FIREPLACE PRODUCTS LTD.
 2975 ALLENBY RD., DUNCAN, BC V9L 6V8



DATE OF MANUFACTURE

100003730

Figure 1: Label, Rating, VISTA Insert LE, - 221019.

Efficiency and BTU Output

EPA Certified Emissions	1.9 grams per hour
LHV Tested Efficiency 1	78%
HHV Tested Efficiency 2	72%
EPA BTU Output 3	13,494 to 23,186 btu/hr.
Maximum Wood Length	17 inches
Ideal Wood Length	16 inches
Fuel	Seasoned Cord wood

1 Weighted Average Lower Heating Value (LHV) efficiency as tested using CSA B415 Performance testing of solid-fuel-burning heating appliances. LHV assumes the moisture is already in a vapour state so there is no loss of energy

2 Weighted Average Higher Heating Value (HHV) efficiency as tested using CSA B415 Performance testing of solid-fuel-burning heating appliances. HHV includes the energy required to vaporize the water in the fuel

3 The range of BTU outputs is based on efficiency using CSA B415 Performance testing of solid-fuel-burning heating appliances and burn rates from the low and high EPA tests using Douglas Fir dimensional lumber.

Experience will give you the right settings for proper combustion and efficient burning. Remember the correct air inlet setting is affected by variables such as type of wood, outside temperature, chimney size and weather conditions. With practice, you will become proficient in operating your heater and will obtain the performance for which it was designed.

Safety

CAUTION: Never use gasoline type lantern fuel, kerosene, charcoal lighter fluid or similar liquids to start or "freshen up" a fire in this heater. Keep all such liquids well away from the heater while it is in use.

Instruct all members of your family on the safe operation of the heater. Ensure they have enough knowledge of the entire system if they are expected to operate it. Stress the section on chimney fires and the importance of following the steps outlined "In Case of Chimney Fire".

Chimney Smoke and Creosote Formation

When wood is burned slowly, it produces tar and other organic vapours, which combine with expelled moisture to form creosote. The creosote vapours condense in the relatively cool chimney flue of a slow burning fire. As a result, creosote residue accumulates on the flue lining. When ignited, this creosote makes an extremely hot fire. The chimney connector and chimney should be inspected periodically (at least once every two months) during the heating season to determine if a creosote buildup has occurred. If creosote has accumulated (3 mm. or more), it should be removed to reduce the risk of a chimney fire.

1. Highest smoke densities and emissions occur when a large amount of wood is added to a bed of hot coals and the air inlet is closed. The heated wood generates smoke, but without ample air, the smoke cannot burn. Smoke-free, clean burning requires small fuel loads, two or three logs at a time or 1/4 to 1/2 of fuel load and leaving the air inlet relatively wide open, especially during the first 10 to 30 minutes after each loading, when most of the smoke generating reactions are occurring. After 30 minutes or so, the air inlet can be turned down substantially without excessive smoke generation. Wood coals create very little creosote-producing smoke.
2. The cooler the surface over which the wood smoke is passing, the more creosote will be condensed. Wet or green wood contributes significantly to creosote formation as the excess moisture that is boiled off cools the fire, making it difficult for the tars and gases to ignite, thus creating dense smoke and poor combustion. This moisture-laden smoke cools the chimney, compounding the problem by offering the smoke the ideal place to condense.

In summary, a certain amount of creosote is inevitable. Regular inspection and cleaning is the solution. The use of dry, seasoned wood and ample combustion air will help to minimize annoying smoke emissions and creosote buildup.

Chimney Fires

The dangerous side effect of excessive creosote buildup is a chimney fire. This causes much higher than normal temperatures in the chimney and on its exterior surfaces. Temperatures inside the chimney can exceed 2000°F (1100°C). Ignition of nearby or touching combustible material is more likely during a chimney fire. Proper clearances are critical to prevent damage during such a fire.

Chimney fires are easy to detect; they usually involve one or more of the following:

- Flames and sparks shooting out of the top of the chimney
- A roaring sound
- Vibration of the chimney

To Avoid a Chimney Fire

1. Burn wood cleanly. Do not burn wet wood or turn down the unit too quickly after loading.
2. Do not let creosote build up to a point where a chimney fire is possible.
3. Do not have fires in the heater that may ignite chimney fires. These are excessively hot fires, such as when burning household trash, cardboard, Christmas tree limbs, or even ordinary fuel wood; (eg. with a full load on a hot bed of coals and with the air inlet wide open for more time than is needed to completely char a fresh fuel load.)
4. The Chimney and connector pipe should be inspected /cleaned periodically.

In Case of a Chimney Fire

1. Prepare to evacuate to ensure everyone's safety. Have a well understood plan of action for evacuation. Have a place outside where everyone is to meet.
 2. Close air inlet on stove.
 3. Call local fire department. Have a fire extinguisher handy. Contact your local municipal or provincial fire authority for further information on how to handle a chimney fire. It is most important that you have a clearly understood plan on how to handle a chimney fire.
 4. After the chimney fire is out, the chimney must be cleaned and checked for stress and cracks before starting another fire. Also check combustibles around the chimney and the roof.
- We recommend the services of professionals who are certified by a “Qualified agency”; such as

**NFI (National Fireplace Institute®) in the United States,
CSIA (Chimney Safety Institute of America) in the United States and Canada,
WETT (Wood Energy Technology Transfer) in Canada or
APC (Association des Professionnels du Chauffage) in Quebec**

Curing of the Paint Finish

To achieve the best finish, the paint on your stove must be baked on. When burning your stove for the first few times it is very important that the room be well ventilated. Open all windows and doors. Smoke and fumes caused by the curing process may cause discomfort to some individuals. See Hang Tag from Forrester Paint.

Disposal of Ashes

Ashes should be placed in a metal container with a tight fitting lid. The closed container of ashes should be placed on a non-combustible floor or on the ground, well away from all combustible materials, pending final disposal. If the ashes are disposed of by burial in soil or otherwise locally dispersed, they should be retained in closed container until all cinders have thoroughly cooled. Other waste should not be placed in this container.

Operation

CAUTION: Hot while in operation. Keep children, clothing and furniture away. Contact may cause skin burns.

WARNING: Always keep loading door closed when burning. This heater is not designed for open door burning.

WARNING: No alteration or modification of the combustion air control assembly is permitted. Any tampering will void warranty and could be very hazardous.

WARNING: Do not use grates or andirons to elevate the fuel. Burn directly on the fire bricks. Replace broken or missing bricks. Failure to do so may create a hazardous condition.

Wood Selection

This heater is designed to burn natural wood only. Higher efficiency and lower emissions generally result when burning air-dried seasoned hardwoods, as compared to softwoods or to green or freshly cut hardwoods.

Wood should be properly air dried (seasoned) for six months or more. Wet or undried wood will cause the fire to smoulder and produce large amounts of smoke and creosote. Wet wood also produces very little heat and tends to go out often. Wood should be stored under cover away from open flame or heat sources.

DO NOT BURN :

• Salt water wood *	• Treated wood
• Wet or green wood	• Coal/charcoal
• Garbage*	• Solvents
• Lawn clippings/yard waste	• Unseasoned wood
• Railroad ties	• Manure or animal remains
• Materials containing rubber, including tires	• Materials containing plastic
• Construction or demolition debris	• Materials containing asbestos
• Waste petroleum products, paints, paint thinners, or asphalt products	• Paper products, cardboard, plywood, or particleboard.

* **These materials contain chlorides which will rapidly destroy metal surfaces and void warranty.**

Burning these materials may result in the release of toxic fumes or render the heater ineffective and cause smoke.

Do not burn anything but wood. Other fuels, eg. charcoal, can produce large amounts of carbon monoxide, a tasteless, odourless gas that can kill. Under no circumstances should you attempt to barbecue in this heater.

The prohibition against burning these materials does not prohibit the use of fire starters made from paper, cardboard, saw dust, wax and similar substances for the purpose of starting a fire in an affected wood heater.

How to Test Your Wood

Add a large piece of wood to the stove when it has a good large bed of coals. It is dry if it is burning on more than one side within one minute. It is damp if it turns black and lights within three minutes. If it sizzles, hisses and blackens without igniting in five minutes it is soaked and should not be burnt.

Lighting a fire

WARNING: Never use chemicals or any other volatile liquid to start a fire. Do not burn garbage, or flammable fluids such as gasoline, naphtha, or engine oil.

1. Adjust air control to "High" position(all the way to the left) and open door.
2. Place crumpled newspaper in the centre of the heater and crisscross with several pieces of dry kindling. Add a few small pieces of dry wood on top.
3. Ignite the paper and leave the door ajar approximately 1/2"(13mm) - 1"(25mm) until the wood kindling is fully engulfed in flame. CAUTION: Do NOT leave the stove unattended while door is open.
4. After the kindling is fully engulfed add a few small logs. Close door.
5. Begin normal operation after a good coal base exists and wood has charred.

Normal Operation

WARNING: This Insert has a manufacturer-set minimum low burn rate that must not be altered. It is against federal regulations to alter this setting or otherwise operate this wood heater in a manner inconsistent with the operating instructions in this manual.

1. Set air control to a desired setting. If smoke pours down across the glass (waterfall effect) this indicates you have shut the control down too soon or you are using too low a setting. The wide range control panel makes finding the desired setting for your application easy. As every home's heating needs vary (ie. insulation, windows, climate, etc.) the proper setting can only be found by trial and error and should be noted for future burns.
 2. To refuel, adjust air control to high, and give the fire time to brighten. Open the door slowly, this will prevent back puffing.
 3. Use wood of different shape, diameter and length (up to 18"(457mm)). Load your wood endwise and try to place the logs so that the air can flow between them. Always use dry wood.
 4. Do not load fuel to a height or in such a manner that would be hazardous when opening the door.
 5. For extended or overnight burns, unsplit logs are preferred. Remember to char the wood completely on maximum setting before adjusting air control for overnight burn.
- Burn wood only, dry and well seasoned. The denser or heavier the wood when dry, the greater its heat value. This is why hardwoods are generally preferred. Green or wet wood will cause a rapid buildup of creosote. If you feel it is necessary to burn wet or unseasoned wood, do so only with the air inlet set open enough to maintain a good strong fire and fairly high chimney temperatures. Do not attempt to burn overnight using green wood or wet wood. Wet wood can cause up to 25% drop in heater output, as well as contributing significantly to creosote buildup.

DO NOT OVERFIRE THIS HEATER:

Attempts to achieve heat output rates that exceed heater design specifications can result in permanent damage to the heater and chimney. A glowing red top or vent pipe are indications of overfiring. Failure to rectify an over firing condition can be hazardous and may void the manufacturer's warranty.

Convection Blower Operation

The Insert comes equipped with a variable speed circulating air blower. The blower is thermostatically controlled for automatic ON/OFF operation, as well as manually with a convenient bypass switch.

Automatic Blower Operation: Allows the blower to turn on automatically once the Insert has come up to operating temperature. It will also shut the blower off after the fire has gone out and the appliance has cooled to below a useful heat output range. Push the rocker switch to the "OFF" position and set the fan speed control to a desired setting.

Manual Blower Operation: Push the rocker switch to the "ON" position and set the fan speed control to a desired setting. This will bypass the temperature switch and allow full control of the blowers.

Suggested settings:

- Combustion air control setting of "L" (low) position (pushed to the far right), operate blower speed control on "Low".
- Combustion air control set at anything above "L" (low), operate blower speed control at desired setting.

Restarting After Extended or Overnight Burns

1. Open door and rake hot embers towards the front of the heater. Add a couple of dry, split logs on top of embers, close door.
2. Adjust air control to high and in just a few minutes, logs should begin burning.
3. After wood has charred, reset air control to desired setting.
4. To achieve maximum firing rate, set control to high "H". Do not use this setting other than for starting or preheating fresh fuel loads.

Proper Draft

1. Draft is the force which moves air from the appliance up through the chimney. The amount of draft in your chimney depends on the length of the chimney, local geography, nearby obstructions and other factors.
Recommended flue draft is between .06" w.c. - .09" w.c. when hot, on high
2. Too much draft may cause excessive temperatures in the appliance. An uncontrollable burn or a glowing red stove part or chimney indicates excessive draft.
3. Inadequate draft may cause back puffing into the room and plugging of the chimney. Smoke leaking into the room through appliance and chimney connector joints indicates inadequate draft.

Remember the correct air inlet setting is affected by variables such as type of wood, outside temperature, chimney size and weather conditions.

Ash Removal

Caution: Ashes are to be removed only when the heater is cold. Whenever ashes get 3"(76mm) to 4"(102mm) deep in your firebox, and when fire has burned down and cooled, remove excess ashes. Leave an ash bed approximately 1" (25 mm) deep on the firebox bottom to help maintain a hot charcoal bed.

See section "Disposal of Ashes" on page 5.

Maintenance

WARNING: ONLY USE MATERIALS SUPPLIED BY MANUFACTURER WHEN DOING MAINTENANCE OR REPLACEMENTS.

Door Gaskets -

The gasket used by Pacific Energy (3/4"(19mm) Firm density fiberglass rope) requires only light pressure to seal. This will prolong seal life. It is important that the door seal be maintained in good condition. Periodically inspect seals and replace if necessary. Follow the instructions included in the kit (prt# 80000670). The kit can be obtained from your nearest Pacific Energy dealer.

Door Glass -

Do not slam loading door or otherwise impact glass. When closing door, make sure that no logs protrude to impact the glass. If the glass gets cracked or broken, it must be replaced before using the stove. Replacement glass can be obtained from your dealer. Use 10-1/2"(267mm) x 16-1/2"(419mm) x 5 mm. Ceramic glass only. Do not substitute with any other type.

To remove broken glass, undo the four retaining screws and remove the clamps and frame, noting position for re-assembly. Remove all particles of glass. Be careful as they are very sharp. Install new glass complete with gasket. Replace frame, clamps and screws.

CAUTION:

- do not overtighten, tighten screws very carefully
- do not clean glass when hot
- do not use abrasive cleaners on glass

1. If glass becomes darkened through slow burning or poor wood, it can readily be cleaned with fireplace glass cleaner when stove is cold. Never scrape with an object that might scratch the glass. The type and amount of deposit on the glass is a good indication of the flue pipe and chimney buildup. A light brown dusty deposit that is easily wiped off usually indicates good combustion and dry, well-seasoned wood and therefore relatively clean pipes and chimney. On the other hand, a black greasy deposit that is difficult to remove is a result of wet and green wood and too slow a burning rate. This heavy deposit is building up at least as quickly in the chimney.
2. The area where boost combustion air enters the firebox must be kept clear of excessive ash buildup which will block air flow. This area is at the front of the firebox.
3. Do not store wood within heater installation clearances, or within the space required for fuel loading. Keep the area around the heater clean and free of loose combustibles, furniture, newspapers, etc.
4. If the plated door requires cleaning, use mild soap and water only. Use of abrasive cleaners will void warranty.
5. Establish a routine for the fuel, wood burning and firing technique. Check daily for creosote buildup until experience shows how often you need to clean to be safe.
6. Be aware that the hotter the fire, the less creosote is deposited. Weekly cleaning may be necessary in mild weather, even though monthly cleaning is usually enough in the coldest months when burning rates are higher. When wood is burned slowly, it produces tar and other organic vapours, which combine with expelled moisture to form creosote.

Maintenance Checks

Check the following parts for damage such as cracks, excessive corrosion, burned out sections and excessive warping: (See website for descriptions and more detail)

Weekly:

- Firebrick - Visual, for cracking.
- Door Gasket - sagging, placement, damage.

Monthly

- Brick Rail Tabs and Brick Rails.
- Air Riser Tube in the back of the firebox.
- Back side of Airwash Chamber.
- Baffle Locking Pin.
- Baffle Tubes
- Boost Tube Cover

When Cleaning the Chimney System:

- Top Baffle Board / Blanket.
- Baffle.
- Top Heat Shield and mounting bolts.
- Baffle Gasket.
- Brick Rails.
- Manifold.

Blower:

- The blower should be cleaned out a minimum every six months by using a vacuum on the grill openings in the back and bottom of the blower casing to remove any dust and debris.

Baffle:

- Some warping of the baffle is normal(up to 1/4" or .65cm). Replace if the baffle has permanent warping greater than this or has cracking or breakage.
- Please contact your Dealer if you experience any of the damage listed above. Continuing to operate your stove with broken parts can accelerate damage to other parts and may void your warranty

Baffle Removal

Chimney connector pipe should be disconnected from stove to clean and inspect. Only if this is not possible should you remove baffle assembly.

DO NOT OPERATE WITH BAFFLE ASSEMBLY, TUBES OR INSULATION REMOVED.

Baffle Removal

1. Slide the Ceramic Board located above the tubes towards the front of the stove. Remove retaining pin at the back of the firebox, just under the baffle.
2. Lift the Baffle up to disconnect from the Baffle supply tube.
3. Move the Baffle to one side then tilt it sideways to drop down and remove from firebox. You may need to remove the opposite side brick rail to allow the Baffle to drop down. - To remove the Brick Rail, remove the brick directly under it then lift the rail up and inward to clear the locating pins
4. Inspect the gasket between baffle and supply tube. If necessary, replace with gasket (prt#80000365) available from your Pacific Energy dealer.
5. Re-install baffle assembly in reverse order. The two side pieces of blanket insulation must be tight against the side rails. The Ceramic Board on top of the tubes must be pushed back tight against the Baffle.

Tube / Baffle Board Removal

1. With a set of vise-grips, grasp the front baffle tube on the right, slightly away from the baffle air assembly. While squeezing tightly, use a hammer to hit the pliers and pull the tube to the right to disengage the tube from the hole on the left. Allow the tube to hang freely from the hole on the right.
2. Repeat step #1 for rear baffle tube.
3. Grasp the front edge of the baffle board and pull forward. Guide the board down and through the door opening. **Caution - Baffle Board material is very fragile.**

Installation

1. With the holes facing down/forward and the notch to the left side, insert a baffle tube into the hole in the baffle air channel on the right at an angle and then raise and insert into the opposite hole on the left side baffle air assembly.
2. With a set of vise-grips, grasp the baffle tube on the left, slightly away from the baffle air assembly. While squeezing tightly, use a hammer to hit the pliers and push the tube to the left to engage the tube in the hole on the left.
3. With the rear tube installed, Insert the baffle board above the tube, between the tube and the side hold down tabs.
4. Repeat steps #1 & #2 with the remaining baffle tube, being careful not to damage the board.
5. Slide the baffle board back until the lower edge is tight against the baffle.

Dimensions

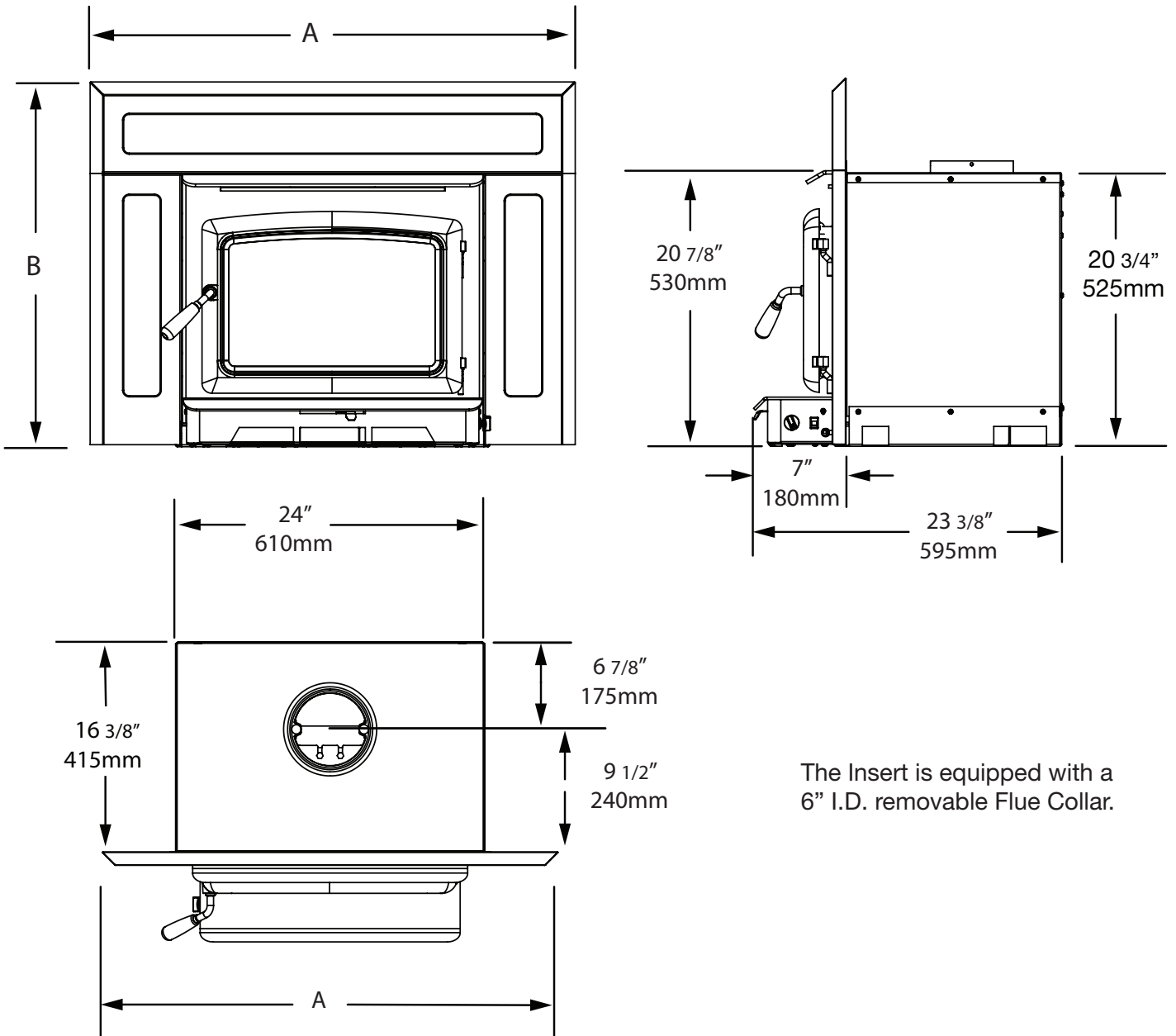

The Insert is equipped with a 6" I.D. removable Flue Collar.

Figure 2: Vista Insert LE - dimensions.

Surround Dimensions		
	REGULAR SURROUND	OVERSIZED SURROUND
A	37" / 965mm	42" / 1070mm
B	28" / 710mm	30" / 760mm

Minimum Fireplace Dimensions

Hearth Requirements:

The fireplace's non-combustible masonry hearth must extend 16" in front and 8" beyond each side of the existing fireplace opening. See Figure 23.

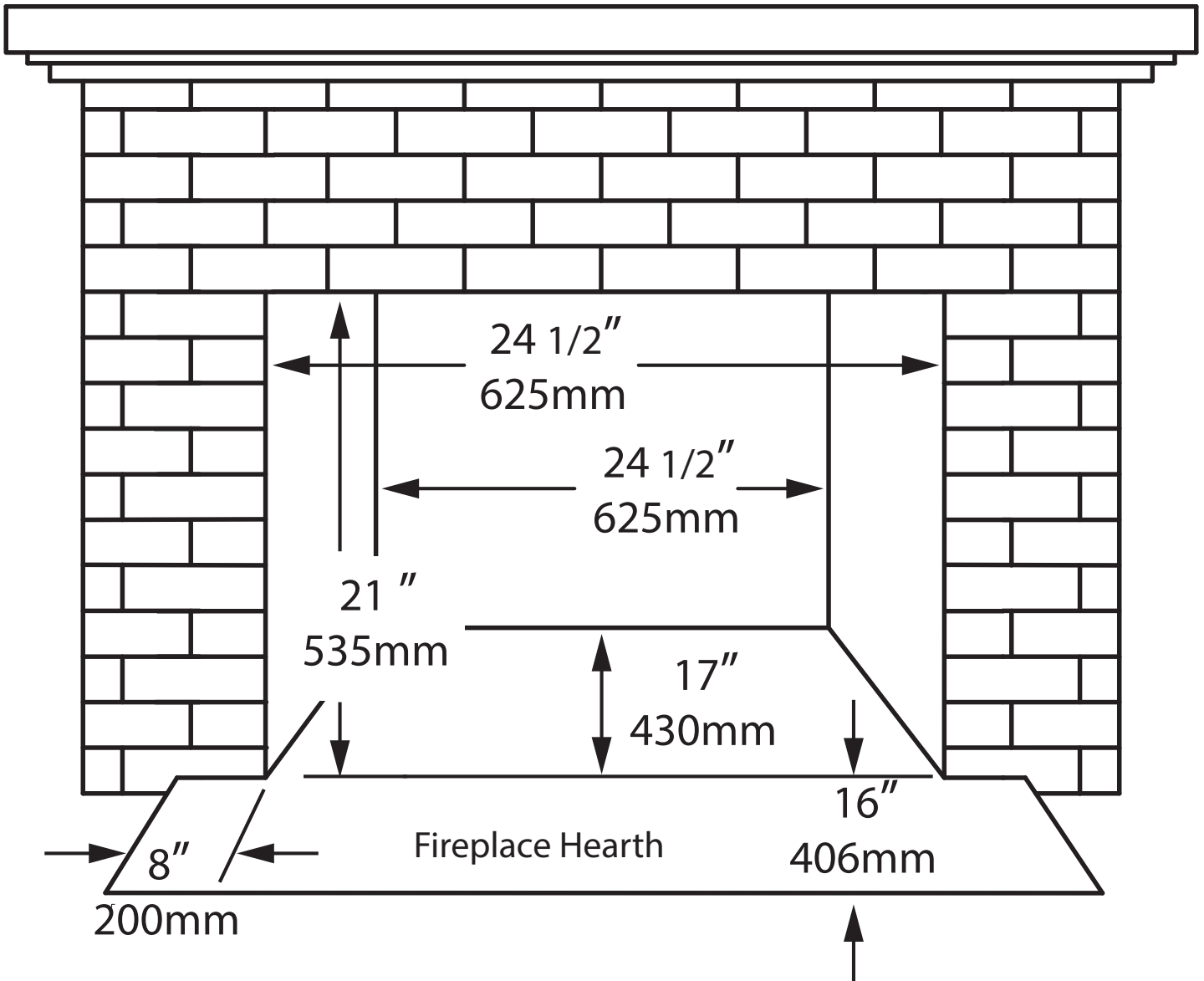

Figure 3: Fireplace opening dim. - VISTA Insert LE.

Ember Protection:

Combustible flooring in front of the fireplace insert must be protected from hot embers by non-combustible material extending;

- Canada - 18" to the firing side (From the Glass) and 8" to each side of the unit.
- U.S.A. - 16" to the firing side (From the Glass) and 8" to each side of the door opening.

Consult CAN/CSA-B365 Installation Code for Solid-Fuel-Burning appliances and equipment in Canada, and N.F.P.A. 211 Standard for chimneys, fireplaces, vents and Solid-Fuel-Burning appliances in USA.

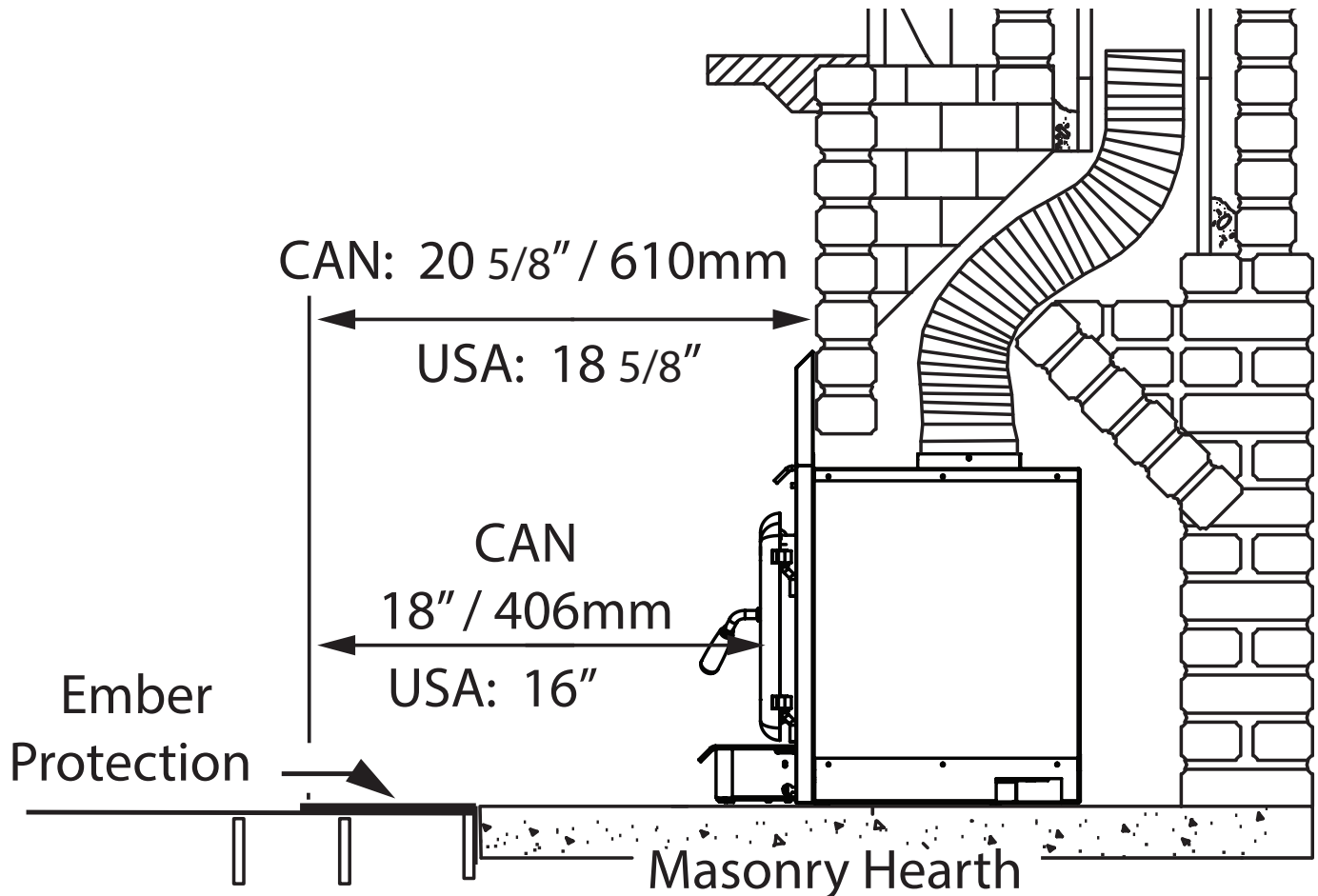

Figure 4: Vista Insert LE - Ember protection.

Optional Leveling Legs

Leveling legs(bolts) are provided if you need them to level or steady the insert on an uneven hearth.

- If your fireplace is lower than the hearth mount the rear leveling leg bolts. Prop the unit up to access threaded inserts under the sides towards the rear of the unit. Thread supplied bolts into inserts, set depth to correspond to depth of fireplace drop.
- If your hearth is lower than the fireplace floor install the front leveling bolts. Prop the unit up to access the threaded inserts under the front, towards the sides of the unit. Thread the supplied bolts into inserts.
-

Push the Insert into position in the fireplace and adjust the leveling bolts as needed to level the Insert.

Clearances

The minimum required clearances to surrounding combustible materials when installed into a masonry or factory built fireplace are listed below and in Figure 4.

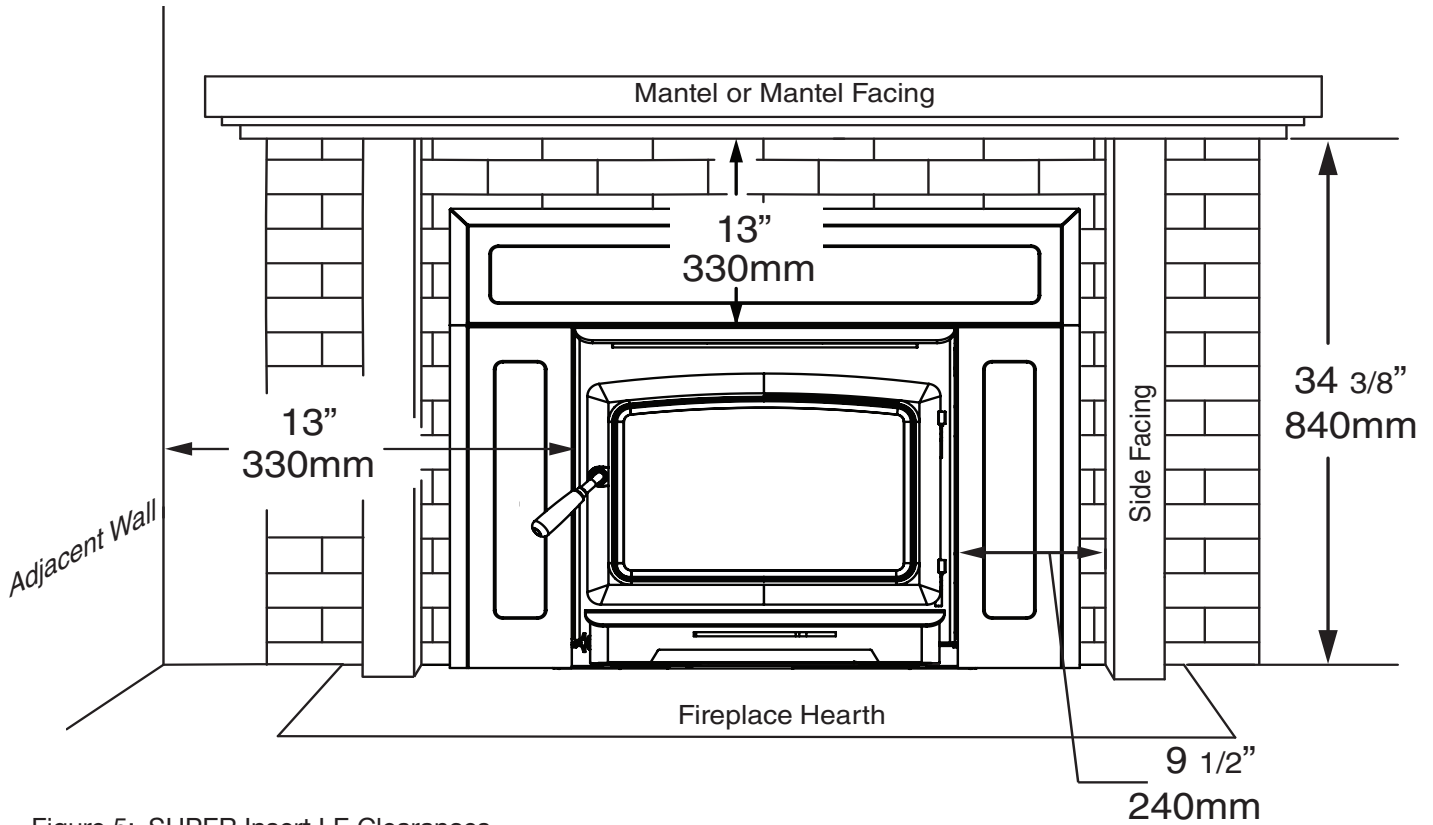

Figure 5: SUPER Insert LE Clearances.

Minimum Clearances to Combustibles

Side of Door to Adjacent Sidewall.....13 in.(255 mm.)
Side of Door to Side Facing (max 3-1/2 in. deep).....9-1/2 in.(155 mm.)
Top to Mantel Facing.....13 in.(305 mm.)
Top to Mantel (max 12in. deep).....13 in.(305 mm.)

CAUTION: Unit hot while in operation. Parts of the appliance, especially the external surfaces, will be hot to touch when in operation. Keep children, clothing and furniture away. Contact may cause skin burns.

Installation

Your Insert is designed to be installed into a masonry or factory built zero-clearance wood burning fireplace. The masonry fireplace and chimney must be good working condition and built according to the requirements of the Standard of Chimneys, Fireplaces, Vents and Solid Fuel Burning appliances, N.F.P.A. 211 (Latest Edition) or applicable National, Provincial, State or local codes. The installation shall conform to CAN/CSA-B365, Installation Code for Solid-Fuel-Burning Appliances and Equipment. The factory built zero-clearance fireplace and its chimney must be listed per UL 127 or ULC S610 standards.

Warning: Under no circumstances is this heater to be installed in a makeshift or "temporary" manner.

DO NOT CONNECT THIS UNIT TO A CHIMNEY FLUE SERVICING ANOTHER APPLIANCE.

Fireplace Specifications

See page 12 for the fireplace minimum size.

Chimney height (from hearth) 15' (minimum).

- The fireplace and chimney system must be suitable for wood burning use. Check for creosote build up or other obstructions. **Have the chimney swept and inspected.** Inspect your fireplace for cracks, loose mortar or other physical defects. If repairs are required, they should be completed before installing your insert.
- **The Insert must be installed in accordance with local and or national building codes.**

We recommend that our products be installed and/or serviced by professionals who are certified by a "Qualified agency";

**NFI (National Fireplace Institute®) in the United States,
CSIA (Chimney Safety Institute of America) in the United States and Canada,
WETT (Wood Energy Technology Transfer) in Canada or
APC (Association des Professionnels du Chauffage) in Quebec**

Caution:

- The fireplace insert is heavy and should be installed by two people.
- Place cardboard or heavy blanket on the hearth to prevent damage while installing.

Into a Masonry Fireplace

The existing fireplace damper is to be locked open or removed completely.

WARNING: Do not remove bricks or mortar from your existing fireplace.

- **Exception:** Masonry or steel, including the damper plate, may be removed from the smoke shelf and adjacent damper frame if necessary to accommodate a chimney liner, provided that their removal will not weaken the structure of the fireplace and chimney, and will not reduce protection for combustible materials to less than that required by the National Building Code.

A metal tag is provided and is to be fastened to the back wall of the fireplace, If the fireplace has been modified to accommodate the insert.

Full Flue Liner - (Required in Canada)

In Canada, this Fireplace Insert must be installed with a continuous chimney liner extending from the Fireplace Insert's Flue Collar to the top of the chimney. The chimney liner must conform to the class 3 requirements of CAN/ULC-B365, Standard for Lining Systems for Existing Masonry or Factory-Built Chimneys and Vents, or CAN/ULC-S640, Standard for Lining Systems for New Masonry Chimneys. The Insert is equipped with a 6" I.D. Flue Collar.

1. Measure the chimney height from the top of the existing Chimney flue to the floor of the hearth. This will allow extra length of liner for flashing and rain cap.
2. Feed the stainless steel liner from top of the chimney, through the damper area and into the fireplace cavity. Attach a "stove to liner" adapter to the bottom of the liner as per the liner manufacturer's instructions.
3. The Flue Collar is packaged in the stove. Attach the Flue Collar to the liner adapter and secure with three Stainless screws. Caulk around connections with high temp stove cement. Ensure the gasket is in good working shape.
4. Push unit into the fireplace. Use the front or rear adjustment legs to level the insert depending on your hearth configuration. (NOTE: Adjustment legs nuts are located in the bottom sides, front and rear of the insert).
5. Remove the Baffle See "Baffle Removal" on page 11
6. Reach through the flue opening and pull down on the Flue Collar with the tool provided until the bolts pass through the mounting slots in the flue opening. Install the clamps and nuts. Center the collar on the opening and tighten the nuts.
7. Measure, trim and shape a Chimney top flashing to fit the existing chimney flue. Plan for a 1" to 1-1/2" overlap on each side. Place flashing over top of the liner and seat firmly against the flue tile.
8. Attach a rain cap to the end of the liner. A storm collar may be used if desired.
9. Install the surround See "Surround Assembly and Installation" on page 21.

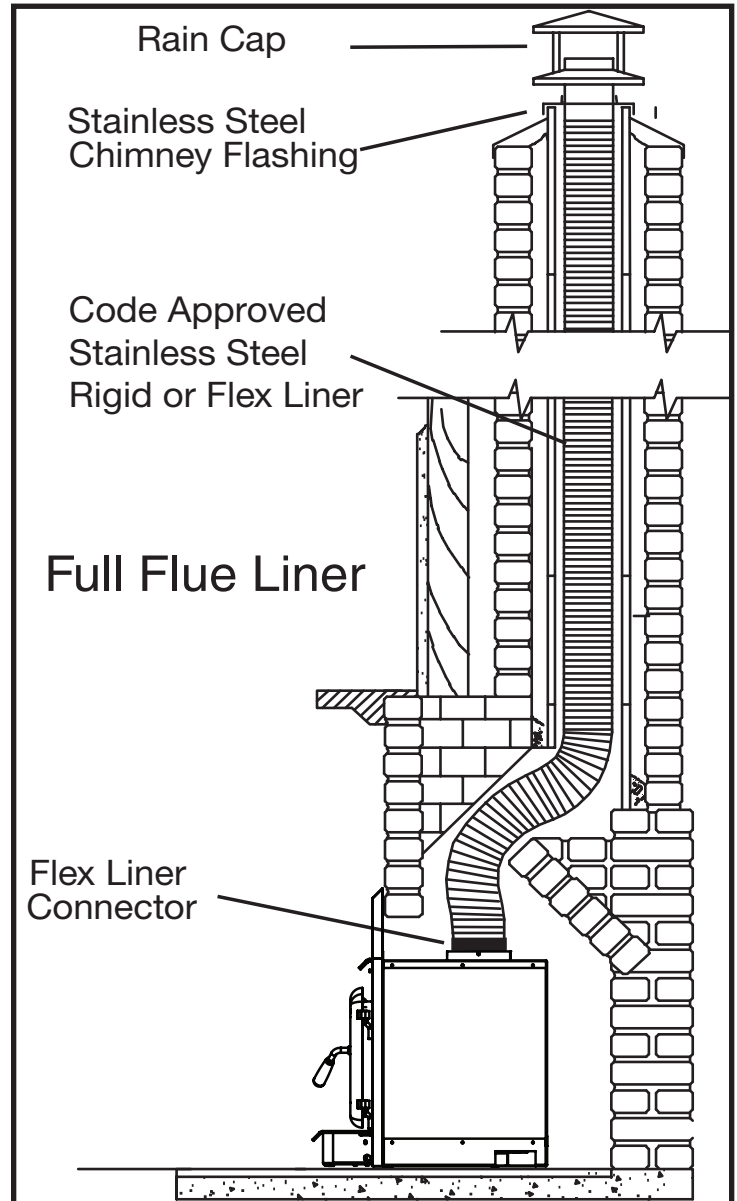

Figure 6: Vista Insert LE - full flue liner.

Direct Flue Connection (permitted only in the USA)

Pacific Energy highly recommends the use of a full liner as the safest installation and providing optimum performance. When connected to a full liner, the Insert is able to draft correctly and will prevent problems such as difficult start-ups and smoking out the door.

Note: A clean-out door may be required under local codes, when a direct flue connection is used. Consult local codes. A seal must be provided in the chimney throat.

1. Measure from the top of the first chimney flue liner tile to the top of the Insert. Allow extra length of liner to insert into flue tile.
2. Feed the stainless steel liner through the damper area and into the first chimney flue tile. Attach a “stove to liner” adapter to the bottom of the liner as per the liner manufacturer’s instructions. Seal around where the liner passes thru in the Chimney Throat.
3. Follow steps 3-9 on the previous page.

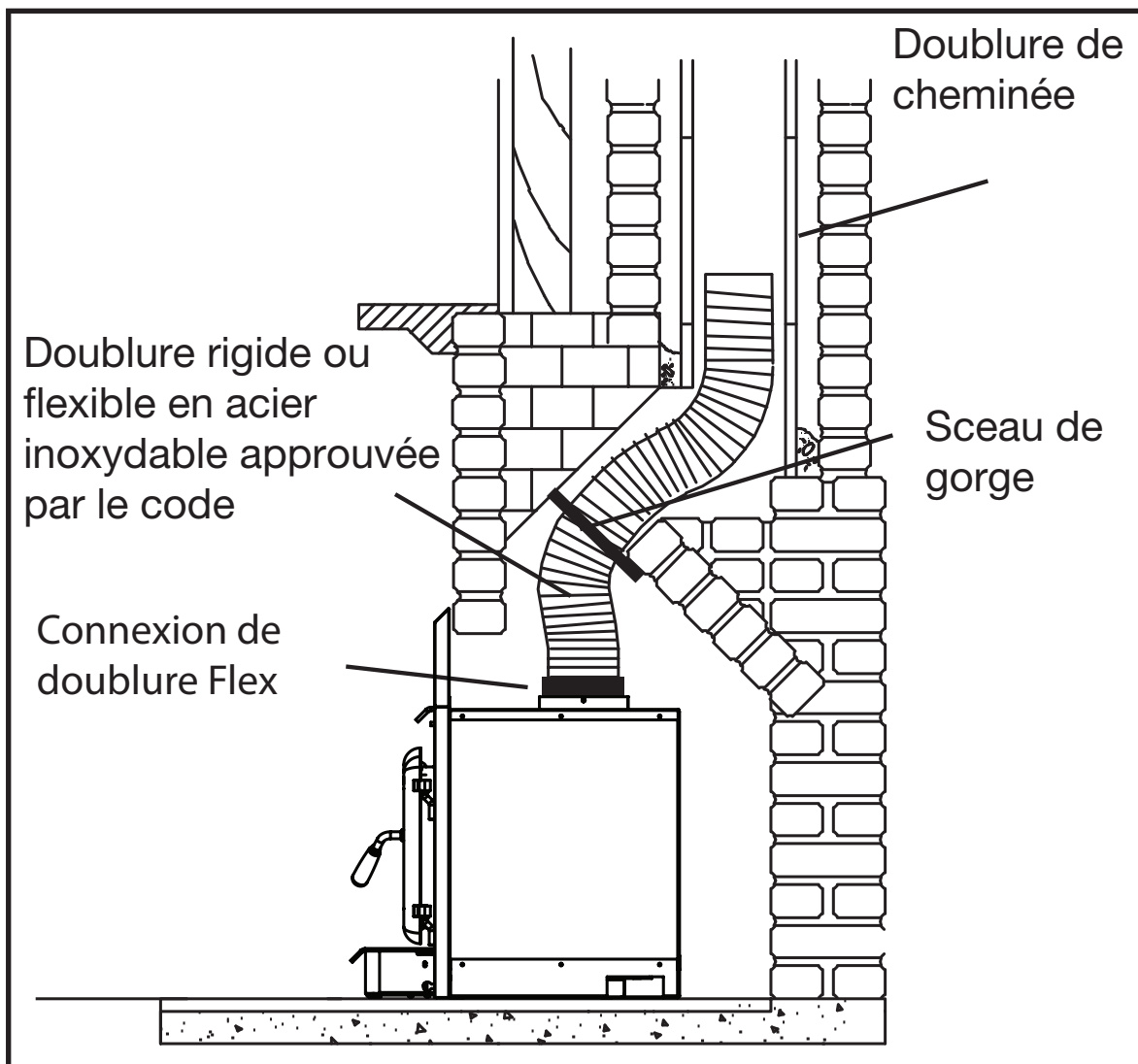

Figure 7: Vista Insert LE - direct flue connection.

Into a Factory Built Fireplace

Your Insert may be installed into a factory built fireplace (size permitting) with the following requirements:

1. Inspect your fireplace for damage or other physical defects. The fireplace must be in good working condition. If in doubt about its condition, seek professional advice. Check for creosote build up or other obstructions inside the chimney, especially if it has not been in use for some time. Before installing, clean your chimney system thoroughly.
2. A full stainless steel rigid or flexible flue liner meeting type HT requirements (2100°F) per UL1777 (U.S.) or ULC S635 (Canada) must be used for both safety and performance. The liner must be securely attached to the Insert flue collar and the chimney top.
3. The surround must be sealed to the fireplace front or the damper area around the chimney liner must be sealed to prevent room air entering the chimney cavity of the fireplace.
4. The air flow within and around the fireplace must not be altered by the installation of the Insert (i.e. no blockage of louvers or cooling air inlet or outlet ports). This includes the circulating air chambers in a steel fireplace or metal heat circulator.
5. Alteration of the fireplace in any manner is not permitted with the following exceptions:
 - External trim pieces which do not affect the operation of the fireplace may be removed and stored on or within the fireplace for re-assembly if the Insert is removed.
 - The chimney damper may be removed to install the liner.

Combustion Air

Consult local building codes regarding combustion air supply. Intake or combustion air can be supplied to the Insert in one of two ways:

1. Outside air supply: Remove the cover from ash clean out in your existing fireplace. Place a rodent screen in place of the cover. Install the Insert as described in the "Installation" section, making sure not to cover the opening of the air inlet. When installation is complete, seal surround to fireplace face and anywhere else air may enter. This will ensure combustion air is drawn from outside the house and into the intake on the bottom of the appliance.

Room air supply: The unit is designed to draw air for combustion in through the bottom of the unit.

Blowers

The Insert has two circulating air blowers located under the Ash Shelf in front of the unit. For your protection against shock hazard, use only a properly grounded outlet that will accept a three-pronged plug. Do not cut or remove the grounding prong. Do not route power cord under unit. Power cord must be routed to avoid contact with any hot or sharp surfaces.

Consult local codes or, in the absence of local codes, with the current CSA C22.1 Canadian Electrical Code and in the USA with the National Electrical Code, ANSI/NFPA 70 (latest edition).

- Electrical rating; 120V, 60 Hz, 1.2 A

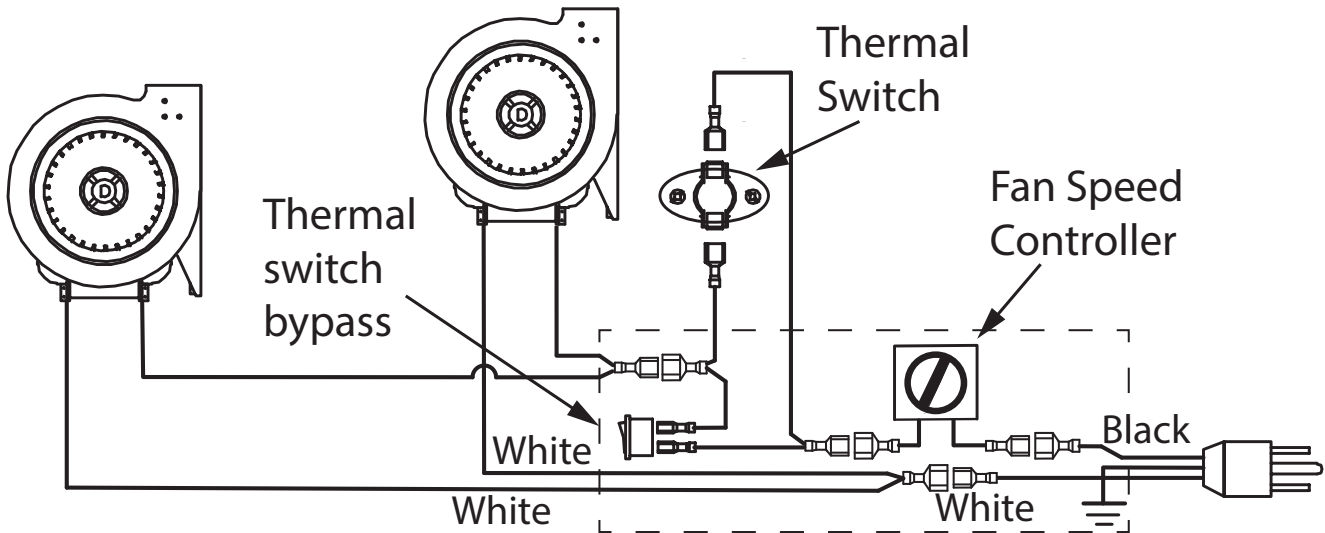

Figure 8: Vista Insert LE - Wiring Diagram.

Blower Service/Replace

Vacuum out the front grill to remove dust and pet hair.

To remove the blowers;

Unplug the unit. Remove the screw located on each side of the Blower Box, under the ashself. (Figure 9).

Gently pull the Blower Box / Ash Shelf assembly towards you, tilting forward to allow it to pass over the Primary Air Control.

Installation is the reverse. Be careful not to bend the Primary Air Control when inserting in through the Blower Box.

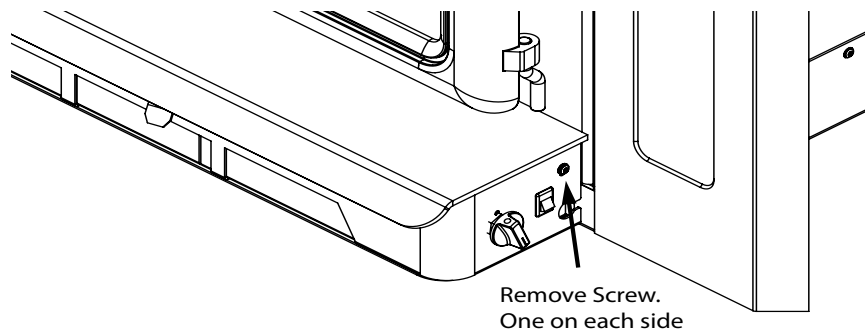

Figure 9: Blower Box Removal.

Surround Assembly and Installation

1. Carefully unpack the Surround Top. Lay parts A, B and C face down on a flat, non-marring surface.
2. Fasten the panels together with 1/4" x 1/2" bolts and nuts provided through holes at points "D" (Figure 10).
3. Lift the surround assembly to the upright position and make sure the front face is flat and even at the joints and sides.
4. Carefully slide the assembled surround over the unit and Ash Shelf, engage the tabs on the inside, back of the surround into the slots in surround brackets located on the side of the firebox.
5. Push the entire appliance back until the surround assembly is in contact with the fireplace face.

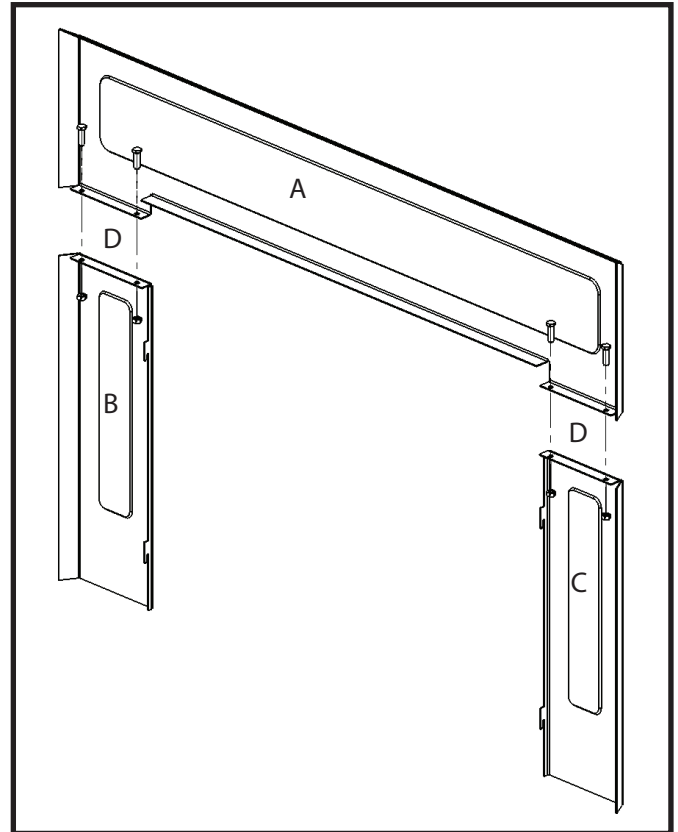

Figure 10: Surround assy.

Troubleshooting

Problem	Cause	Cure
Glass is Dirty	<ol style="list-style-type: none">1. Wood is wet2. Turning down air control or damper too soon3. Draft too low<ul style="list-style-type: none">- Chimney plugged or restricted.4. Door gasket leakage	<ul style="list-style-type: none">- Use dry wood- Do not turn down until<ol style="list-style-type: none">a) there is a good bed of coalsb) the wood is charred- Improper chimney height and / or diameter- Inspect and clean- Provide outside air for combustion- Replace gasket- Check latch
Excessive Creosote Buildup - See 1,2,3, above.		
Low Heat Output	<ol style="list-style-type: none">1. Wood is wet2. Fire too small3. Draft too low	<ul style="list-style-type: none">- Use dry wood- Build a larger fire- Chimney plugged or restricted, inspect and clean
Won't Burn Overnight	<ol style="list-style-type: none">1. Air control is set too high2. Not enough wood3. Draft too high4. Door gasket leaking	<ul style="list-style-type: none">- Set control lower- Unsplit wood is preferred for overnight burns- Excessive chimney height and/ or diameter- Replace door gasket.
Stove Won't Burn	<ol style="list-style-type: none">1. Combustion air supply blocked2. Draft too low	<ul style="list-style-type: none">- Check outside air supply for obstruction- Check that room air cover is removed- Chimney plugged or restricted, inspect and clean- Chimney oversized or otherwise unsuitable,- Consult Dealer

Firebrick Installation

ITEM	Dimensions
A	8 7/8" x 4 3/8" x 1 1/4"
B	8 7/8" x 2 1/8" x 1 1/4"
C	4 1/4" x 2 1/8" x 1 1/4"
D	4 3/8" x 3 1/4" x 1 1/4"
E	7" x 3 1/4" x 1 1/4"

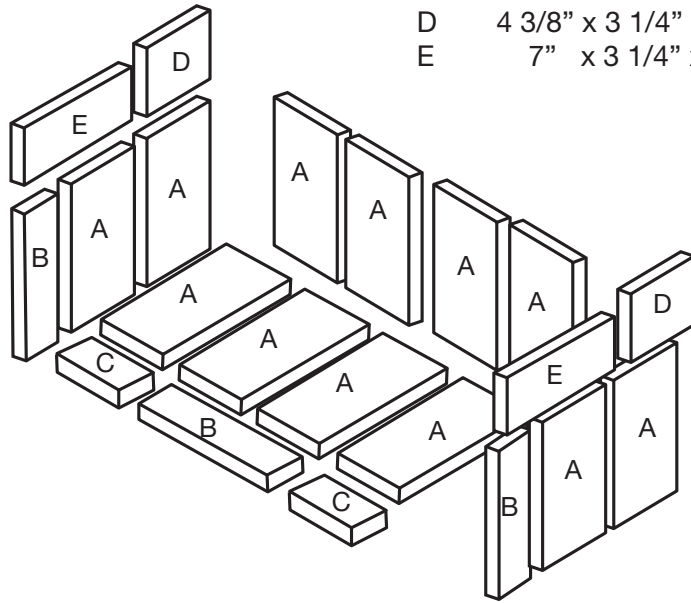

Figure 11: Vista Insert LE - Firebrick layout.

Firebrick Installation

1. Beginning at the rear wall, stand one "A" firebrick vertically behind the tab located on the brick rail. Slide the firebrick toward the center of the rear wall.
2. Slide a 2nd "A" firebrick underneath the tab on the brick rail (Figure 12). Repeat steps 1 & 2 for the other side (Figure 13).

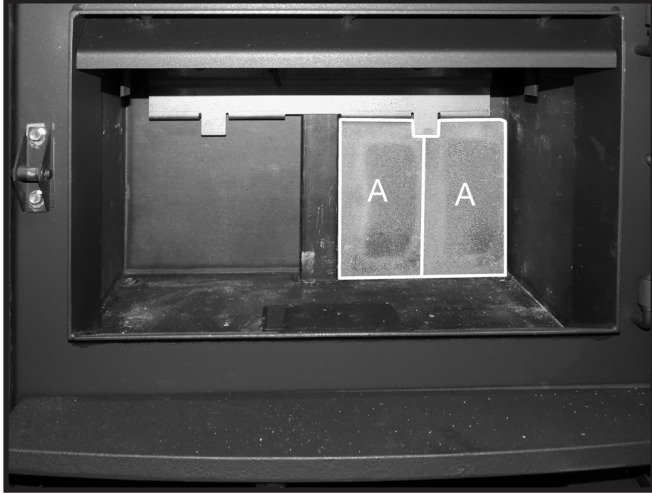

Figure 12: Installing the two rear wall firebricks.

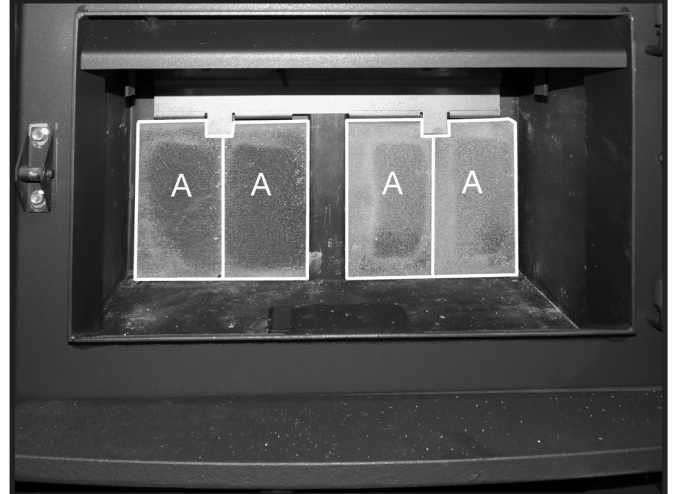

Figure 13: Remaining rear wall firebricks in place.

3. For the side walls: Stand an "A" firebrick against the side wall and up against the rear wall firebrick (Figure 14). Stand another "A" brick beside the first, one followed by a narrow "B" firebrick (Figure 15).

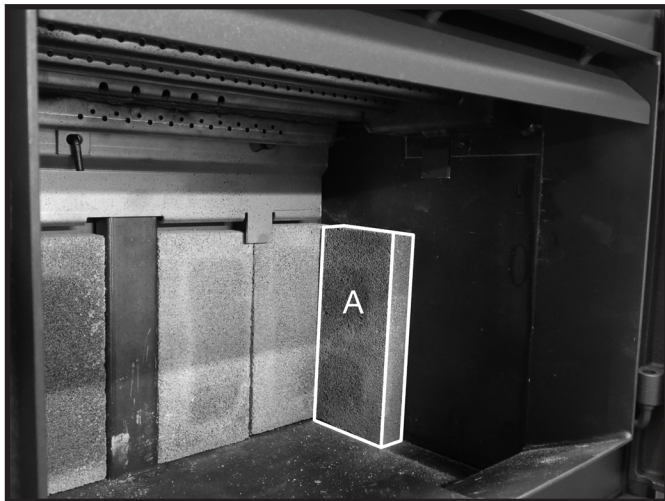

Figure 14: 1st side wall brick in place.

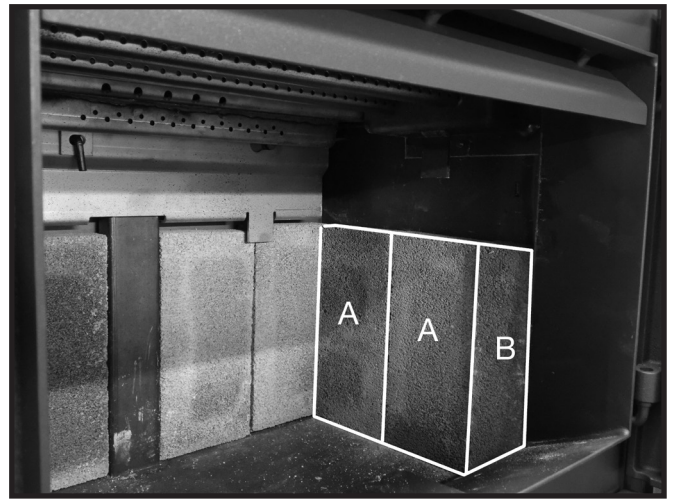

Figure 15: Lower side wall firebricks in place.

- Place a "D" firebrick on top of the previously placed "A" firebricks and slide this firebrick back toward the rear wall making sure that this firebrick tucks in behind the brick rail (Figure 16).
- Slide an "E" firebrick under the side wall brick rail tab and rest on top of the three previously placed side wall firebricks (Figure 17). Repeat steps 4-7 on the other side.

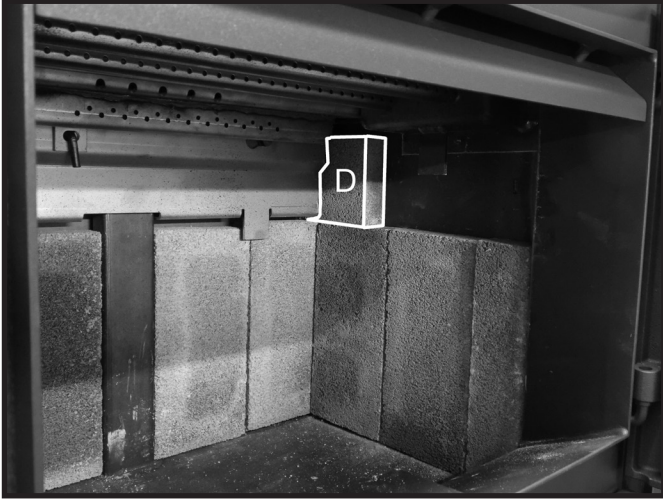

Figure 16: Small side wall firebrick in position.

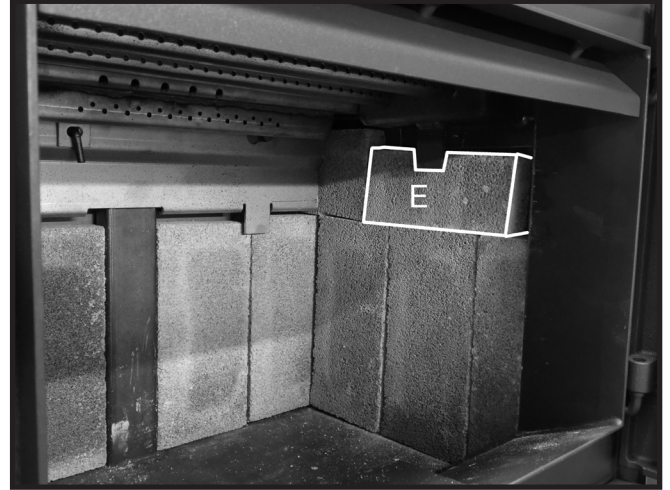

Figure 17: Final side wall firebrick in position.

- Place four "A" firebricks on the firebox floor as shown in Figure 18.
- Place the remaining "B" firebrick so that it sits in front and at the center, add a "C" brick on each side. (Figure 19).

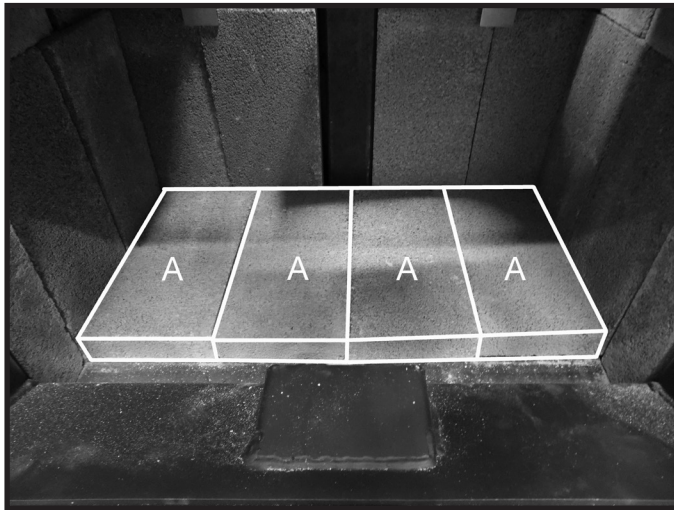

Figure 18: Four floor bricks in place.



Figure 19: Narrow front bricks in place.

Replacement Parts

(WHEN ORDERING, INCLUDE PART NUMBER WITH DESCRIPTION)

.....ITEM DESCRIPTION PART #

1.....	Surround, Vista Insert LE, Standard	11250045
2.....	Surround, Vista Insert LE, Oversized	11250037
3.....	Door catch, Vista LE	80002387
4.....	Ashlip (c/w hardware)	80002437
5.....	Ashlip Mounting Bracket	
6.....	Blower, 45mm x 120mm Wheel, RHS	80001396
7.....	Blower, 45mm x 120mm Wheel, LHS	80001397
8.....	Switch, Fan, 120-10, Air Mount.....	80001814
9.....	Switch, Rocker, SPST On/Off	80001513
10....	Switch, Rheostat	80000908
11....	Air Control, Primary	80002438
12....	Firebrick, NEO 1.6 LE / Vista LE (set)	80002355
13....	Glass(c/w Tape), NEO 1.6	80000220
14....	Glass Retainer, NEO 1.6 / Vista LE	80002356
15....	Gasket, Door, NEO 1.6/ Vista LE	80000670
16....	Casting, Door, Vista LE, Black	80002394
.....	Casting, Door, Vista LE, Nickel	80002395
.....	Casting, Door, Vista LE, Brushed Nickel	80002396
17....	Door handle assembly	80000660
18....	Door Assembly, Met Black	11190026
.....	Door Assembly, Nickel.....	11190025
.....	Door Assembly, Brushed Nickel	11190024
19....	Tube Air Box Gasket, NEO 1.6 LE / Vista LE	80002359
20....	Tube Air Box (RHS), NEO 1.6 LE / Vista LE	80002365
21....	Tube Air Box (LHS), NEO 1.6 LE / Vista LE.....	80002358
22....	Tubes, NEO 1.6 LE /Vista LE (set of 2)	80002364
23....	Baffle Board, NEO 1.6LE / Vista LE	80002357
24....	Flame Shield, NEO 1.6 LE / Vista LE,	80002360
25....	Baffle, Pin, (10pc).....	80000364
26....	Baffle, NEO 1.6 LE / Vista LE.....	80002361
27....	Brick Rail Set, Left/Right, NEO 1.6 LE / Vista LE	80002363
28....	Baffle Blanket (set), NEO 1.6 LE / Vista LE.....	80002362
29....	Rear Brick Rail, NEO 1.6.....	80001723
30....	Gasket, 2" Baffle Tube, 10 pack	80000356
31....	Handle, Removable Collar	80000254
32....	Gasket, Removable Collar	80001983
33....	Flue Collar, Removable, (c/w Hardware).....	80000665

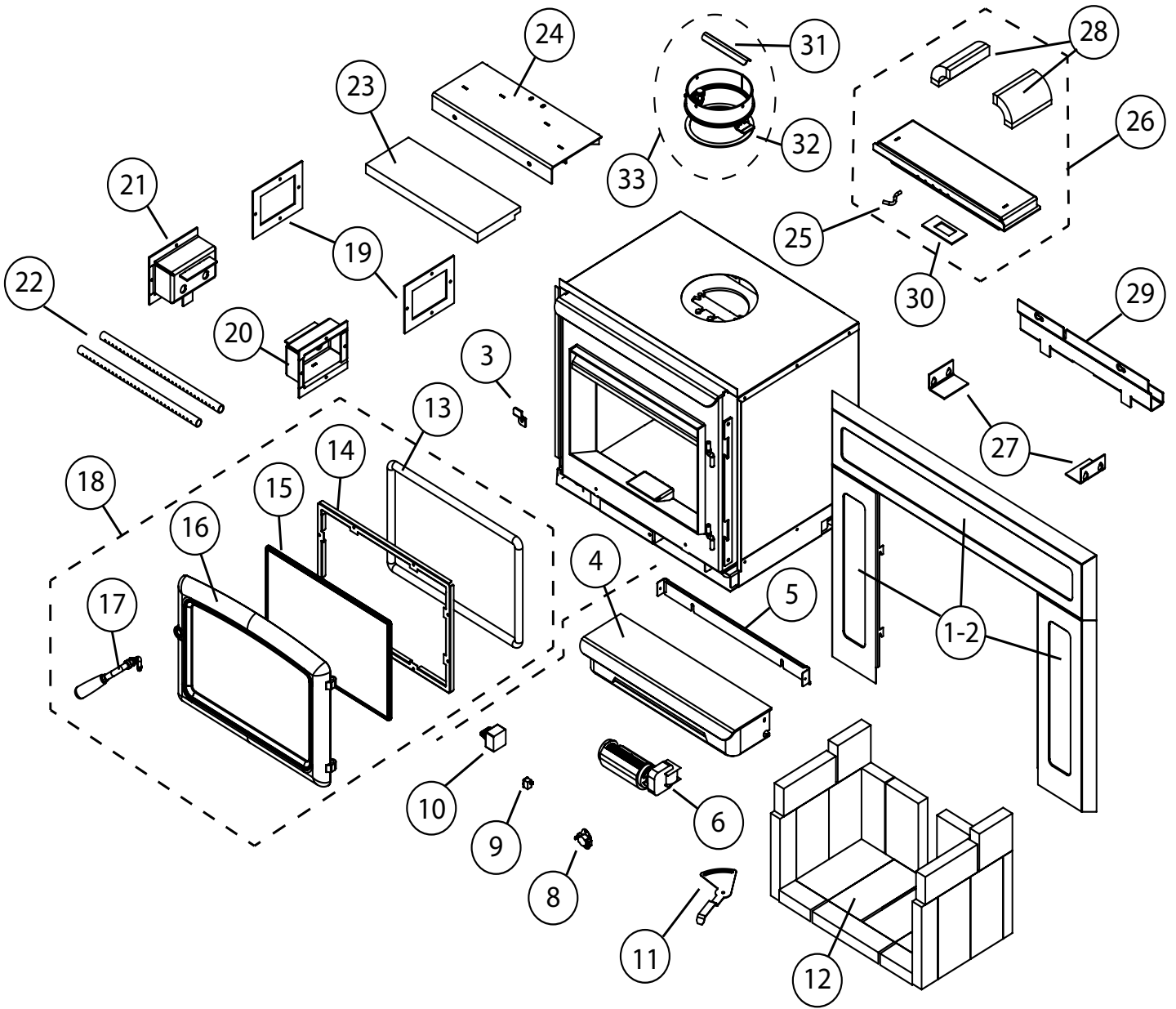

© 2019 Copyright Pacific Energy Fireplace Products LTD.
Reproduction, adaptation, or translation
without prior written permission is prohibited
except as allowed under the copyright laws.



For Technical Support please contact your dealer
Web site: <http://www.pacificenergy.com>

PACIFIC ENERGY FIREPLACE PRODUCTS LTD.
2975 Allenby Rd., Duncan, B.C. V9L 6V8